



# Nikola Tesla and the Graz Tech

Edited by Uwe Schichler and Josef W. Wohinz

Archive and Library of Graz University of Technology / Vol. 7 EN







## Archive and Library of Graz University of Technology

- Vol. 1 Kriegstagebuch Franz Allmer  
1941 – 1945
- Vol. 2 TU Graz Art Guide
- Vol. 3 verMESSEN  
Franzische Grundkataster von Graz
- Vol. 4 Leseturm TU Graz  
Eine moderne Bibliothek
- Vol. 5 Es rissen alle Stricke – doch wir überlebten  
Episoden aus der Kriegs- und Nachkriegszeit in Wien  
in einer nicht streng chronologischen Abfolge
- Vol. 6 „In diesen schweren Tagen“  
Die Technische Hochschule Graz im Ersten Weltkrieg
- Vol. 7 Tesla Nikola(us) und die Technik in Graz
- Vol. 7 EN Nikola Tesla and the Graz Tech



# Nikola Tesla and the Graz Tech

Edited by Uwe Schichler and Josef W. Wohinz

© 2019 Verlag der Technischen Universität Graz

Publisher: Graz University of Technology/Library and Archive

Translation from the German: Andrew Peaston

Layout: Norbert Prem, [www.derprem.com](http://www.derprem.com)

Cover photo: Robert Illemann Photography, [www.robertillemann.com](http://www.robertillemann.com)

Printed by: Medienfabrik Graz, [www.mfg.at](http://www.mfg.at)

Verlag der Technischen Universität Graz

[www.tugraz-verlag.at](http://www.tugraz-verlag.at)

ISBN (print) 978-3-85125-687-1

ISBN (2020 e-book) 978-3-85125-688-1

DOI 10.3217/978-3-85125-687-1



<https://creativecommons.org/licenses/by-nc-nd/4.0/>



# Nikola Tesla and the Graz Tech

8	Editor's foreword
<b>11</b>	<b>Nikola Tesla and the Graz Tech</b> by Josef W. Wohinz
12	The Graz Tech: A tradition of innovation
14	Nikola Tesla: Milestones in his life
20	Nikola Tesla: Student at the Graz Tech
28	Nikola Tesla: Honorary doctor of technical sciences
37	People shape the development of the Tech
38	References
<b>41</b>	<b>Nikola Tesla: Visionary and Inventor</b> <b>Contributions to scientific and industrial development</b> by Uwe Schichler
42	Development of electrical engineering from 1850 to 1950
43	The problem of the commutator
43	The rotating magnetic field: Polyphase alternating current system
44	The Niagara Falls power station: Direct current or alternating current?
54	High frequency, the Tesla transformer and Wardenclyffe Tower
62	Remote-controlled ships and robots
64	Hotel room 3327 in New York
65	Tesla's innovations: visible in the 21st century
65	References

<b>67</b>	<b>Constant development and unrelenting progress is the goal... Stages in the development of the Universalmuseum Joanneum</b> by Karl Peitler, Wolfgang Muchitsch, Bernd Moser
70	The main reasons behind its establishment and their classification in the history of museums
72	Original scope
73	Outline of the course of development
75	The early Joanneum (1811 to 1887)
82	The Joanneum from 1888 to 2002
87	The State Museum or Universalmuseum Joanneum GmbH: Stepping out into the Future
90	References
<b>91</b>	<b>The architecture of the high-voltage laboratory: An exciting architectural monument to technology</b> by Friedrich Bouvier
94	Design principle
97	Tasks and test facilities
98	Postscript
98	References
<b>99</b>	<b>'Technology is the pride of our age' (Peter Rosegger) A technological history of Graz in the 19th century</b> by Gerhard M. Dienes
118	References
120	List of authors

---

## Editor's foreword

Nikola Tesla can be counted as one of the most brilliant inventors of our age. He ushered in ground-breaking developments, especially in the field of alternating current and high-frequency engineering, wireless information and energy transmission as well as medical technology.

Born in Smiljan in today's Croatia, his life's journey took him to the USA, where he died in New York.

### **There are many links to the Graz Tech**

- From 1875 to 1878, Nikola Tesla was a student at the Imperial and Royal College of Technology, which was located in those days at the Joanneum (Raubergasse 10).
- In 1937, Nikola Tesla was awarded a honorary doctorate in technical sciences by the former Graz-Leoben College of Technology (and Mining).
- In 2006, a plaque was erected at the Joanneum (the former site of the College of Technology) to commemorate Nikola Tesla as a student.
- Also, the large high-voltage hall at Graz University of Technology's Institute of High Voltage Engineering and System Performance was named the Nikola Tesla Laboratory in 2006.
- And finally, the Nikola Tesla Medal has been awarded for special invention achievements at Graz University of Technology since 2015.

Nikola Tesla was born in 1856. On the occasion of his 150th birthday, an exhibition took place at the Institute of High Voltage Engineering and System Performance together with the Universalmuseum Joanneum (previous head of the Institute was Univ.- Prof. Michael Muhr) in 2006.

On the occasion of this event an accompanying booklet and the publication 'Nikola Tesla and the Graz Tech' was published.

Nikola Tesla died in 1943, so 2018 was the 75th anniversary of his death.

A translation and a reissue of the 2006 publication was proposed by Gabriele Groß at the Verlag der Technischen Universität Graz – the publishing house of Graz University of Technology. This work was generously supported by Bernhard Reismann, from the University Archive, with Helmut Tezak providing the photographs.

Thus again a depiction of the personality of Nikola Tesla and his special relationship to the Graz Tech has thus been presented. Of course, his achievements in the field of science and industry are in the foreground. The situation at the former College of Technology and its surroundings will also be illuminated.

The selection made for the overall structure and responsibility for it lies with the editors alone.

The individual articles have been written by outstanding, proven experts on their own authority and represent their own personal points of view.

To begin with, an overview of Nikola Tesla the man – as stated in the entry in his academic file dated 1875 – will be examined.

Subsequently, his contribution to the development of science and industry will be outlined.

This is followed by a portrait of the Universalmuseum Joanneum and its role as a germ cell for technology in Graz.

The description of the large experimental hall at the Institute of High Voltage Engineering and System Performance as an architectural monument to technological development leads to the site of the Nikola Tesla Laboratory at today's Graz University of Technology.

An article on the industrial and technological development of 19th century Graz goes to form the conclusion.

Our thanks go to the authors, who have shaped this publication through their work. Furthermore, we would like to thank all those who made documents available and contributed to the attractive presentation. Special thanks is due to Graz University of Technology under its current rector, Harald Kainz. It provides the platform on which the person of Nikola Tesla can be appropriately honoured.

We look forward to an interested readership both within and beyond the present Graz Tech. We look forward to any comments, suggestions or observations.

Uwe Schichler  
Graz, December 2018

Josef W. Wohinz



# Nikola Tesla and the Graz Tech

by Josef W. Wohinz

---

The Graz Tech:  
A tradition of innovation

Graz University of Technology – Archduke Johann University – is an integral part of the intellectual life of our country. It justifiably counts as one of the centres of scientific research and teaching and thus represents an essential element of our society. In fact, it goes beyond the national aspect and embraces both the European and even the international context of academic institutions (see Wohinz, Josef W. /12/).

When the term ‘Graz school’ is used in many places, it expresses a certain degree of charisma and recognition at the same time. This recognition, of course, refers to the personalities working there as well as to the shared platform of technology and engineering in Graz. The following examples can be referred to here: architecture, civil engineering, automotive engineering and engine construction, engineering management, space research, telematics and microchemistry.

Integration into the overall picture and the role as a university here and today can be seen as a result of a long-term development.

Today’s Graz University of Technology can look back to its beginnings as a foundation of Archduke Johann of Austria in the year 1811. He handed over his scientific collections to the ‘estates’ of the Duchy of Styria and the ‘Joanneum’ named after it became a nucleus of the later development into a university. In the course of an organisational reform in 1827, an ‘academy of the estates’ was established at the Joanneum and the first director of studies (Ludwig Crophius, Edler von Kaiserssieg) was appointed. In 1864 this became the College of Technology at the Joanneum in Graz. In 1872 an organic statute was enacted for the Regional College of Technology at the Joanneum in Graz. Finally in 1874, this was transformed into the Imperial and Royal College of Technology in Graz.

At this time the College of Technology was still located at the seat of the Joanneum, in the so-called Lesliehof at Raubergasse 10.

Only with the festive opening of the new building at Rechbauerstrasse 12 (today’s Alte Technik) was the Lesliehof site discontinued. In a commemorative publication /2/ it is noted:

*'In the presence of the Imperial and Royal Apostolic Majesty of Emperor Franz Joseph I, the grand patron of the arts and sciences, the solemn inauguration of the new building of the Imperial and Royal College of Technology constructed between 1885 and 1888 shall take place in the city of Graz on 12 December 1888.'*



The importance of the specific, indeed unmistakable, character of a university lies in the particularly close link between scholarly research and teaching. In this way, insights are obtained which, as a further development of knowledge and in particular of the respective state of technology, justify the reputation of such an institution. Our world today is crucially shaped by technology, which entails both negative and positive aspects. The shared responsibility for our fellow human beings and for the environment is reflected in necessary decisions and programmes of action derived from them. Here, many contributions have been and are being made.

Fig.: Joanneum (Raubergasse 10) entrance gate with a row of coats of arms and a commemorative plaque (photo: H. Tezak)

At the same time, it also imparts those qualifications which are important for professional use outside the university. The right to confer academic degrees which is reserved for the universities (and recently also universities of applied sciences) emphasises this exceptional status.

It seems now entirely appropriate to cultivate an awareness of tradition at Graz University of Technology and show solidarity with people who have contributed to this development. This will be illustrated by three persons:

- Solidarity with the founder of the Joanneum, Archduke Johann, known as 'the Habsburg green rebel' (according to H. Magenschab /4/) since he founded the nucleus of today's 'Alma mater Joannea'.
- Solidarity with the university employees who once worked here and who established today's reputation. As a representative of them, Richard Zsigmondy, university assistant and Privatdozent (similar to adjunct professor) who held courses on chemical technology from 1893 to 1898, and who was awarded the Nobel Prize in Chemistry 1925 one year later, in 1926, should be mentioned here /3/.
- Solidarity with the young people who studied at this school of higher learning, and among whom Nikola Tesla counted from 1875 to 1878.

He is today, justifiably, seen as one of the most brilliant and imaginative inventors of our age. On account of his achievements, he was awarded a honorary doctorate in technical sciences from the Technical University in 1937.

---

**Nikola Tesla:**  
**Milestones in his life**

Nikola Tesla was born at Smiljan, in the Lika border region (in today's Croatia) on 10 July 1856. At the time of his birth, this region was part of the Austro-Hungarian monarchy. Accordingly, the following formulation is to be found in his later patent applications (in the USA):

'Be it known that I, NIKOLA TESLA, of Smiljan, Lika, border country of Austria Hungary, have invented...'

(Patent No. 355, 786, dated February, 9, 1886).

'Be it known that I, NIKOLA TESLA, a subject of the Emperor of Austria, from Smiljan, Lika, border country of Austria-Hungary, residing at New York, in the county and State of New York, have invented...'

(Patent No. 455, 069, dated June 30, 1891).

Only after he had been given citizenship of the USA did he use the form:

'Be it known that I, NIKOLA TESLA, a citizen of the United States, residing at New York, in the county and State of New York, have invented...'  
(Patent No. 464, 667, dated December 8, 1891).

His parents were Serbs. He came to see himself as one, even after he acquired American citizenship in 1891. His father, who was an Orthodox priest, placed great value on strict mental discipline. His mother had a pronounced practical disposition, which she was able to pass on to her children.

Nikola had three sisters and an older brother who died in an accident at an early age. His parents arranged for Nikola to have a schooling which was excellent for the rural conditions of the time. He attended primary school in Smiljan and Gospić from 1862 to 1866, and then went to the secondary school in Gospić until 1870. He received further schooling at the upper secondary school in Rakovac from 1871 to 1874.

His parents wanted him to follow in the family tradition and become a priest. But this did not suit his own inclinations and interests, which were more oriented to physics. Only in the context of an illness, as a kind of quid pro quo for a promise of recovery, did he manage to receive permission from his parents to study physics.

Nikola Tesla came to Graz at the beginning of the 1875/76 academic year and remained here as a student until 1878. In 1881, he resumed his studies at the University of Prague.

In the autumn of 1881, Nikola Tesla worked as an employee at the telephone exchange in Budapest. In 1882, he joined the Continental Edison Company in Paris, where he was commissioned to co-operate on building a power station at Strasbourg.

In June 1884, Nikola Tesla moved to New York. He immediately began working for Thomas Alva Edison at the Edison Machine Works.

Tesla was initially very impressed by Edison's business acumen. He very quickly developed a variety of standard designs of an improved Edison dynamo, and was promised 50,000 dollars for fulfilling this task. But he was bitterly disappointed when he learned from Edison that this promise had been meant as a joke. For this reason he terminated his co-operation with Edison. Both men were poles apart in character. Edison was business minded, communicative and sought the company of other persons both at work and at leisure. Tesla, in contrast, was described as a neurotic loner, who allowed few people insight into his work. His few friends were mainly writers, one of whom was the American humourist, Mark Twain.

In 1887, the Tesla Electric Light Company was founded. In this company, Tesla was finally able to build the three-phase motors that he had long been thinking about.

By means of the patents which he had meanwhile applied for and been granted, Tesla had become well known, and he was invited to a lecture at the American Institute of Electrical Engineers on 16 May 1888. As a result of the lecture, which aroused great excitement, Tesla made the acquaintance of George Westinghouse, who, similar to Edison, was a well-known entrepreneur. Tesla managed to persuade Westinghouse that the future belonged to alternating current, and not to direct current. In 1888, Tesla's company made an agreement with the Westinghouse company. For the transfer of rights of use of his patents to Westinghouse, Tesla was not only to receive direct compensation, but also a share in the future plants installed by Westinghouse to a specified degree. It has been reported that the Westinghouse company could no longer meet this obligation at a later phase due to commercial difficulties, and that Tesla simply destroyed the relevant contractual agreements in order to aid Westinghouse.

In 1889, Nikola Tesla returned to New York and began experiments in a laboratory to develop high-frequency machines. In this year, he visited the World Exposition in Paris and also his former homeland.

This connection to his earlier homeland can be seen in his patent applications. The data bank of 'privileges' at the Austrian Patent Office in Vienna contains a total of five privileges (at this time a 'privilege' was the name given to the later word 'patent') for the years 1889 to 1890.

These petitions for privileges referred to the following inventions:

- 16.4.1889: Innovations in the transmission of electric power
- 24.4.1889: Innovations in the process and apparatus for converting and distributing electric currents
- 2.4.1890: Innovations in alternating current motors
- 24.9.1890: Innovations in the processes of converting alternating current into direct current
- 27.9.1890: Alternating current motor

Furthermore, Nikola Tesla devoted his attention to experiments on the wireless transmission of messages, which in turn had an impact on numerous patents.

On 13 March 1895, his laboratory in New York, along with the appliances he had developed up until then, was destroyed by a fire. In a report for the Electrical Review, Nikola Tesla stated:

'I was engaged on four main lines of work and investigation. One of these was the oscillator. Another was improved methods of electric lighting. Another was the transmission of intelligence any distance without wires. A fourth, which is an ever present problem for every thinking electrician, touches on the nature of electricity'. But in 1896, he was continuing his scientific investigations and experiments in the field of radio technology in a laboratory in New York.

In 1899 he built a radio station in Colorado which made it possible to send signals by wireless telegraphy over distances greater than 1,000 km. With this idea of the wireless transmission of energy and information, he managed to win over J. Pierpoint Morgan as a financial backer. The project was called Wardenclyffe and its aim was to transmit radio signals between two towers – one on a plot of land on Long Island and the other in England. The project failed, however.

Nikola Tesla registered numerous other patents in the following years, and he continued in this scientific and technical direction until about 1922. Later, his work became increasingly of a general philosophical nature and would become regarded today in many ways as esoteric.

Nikola Tesla died in a New York hotel room, probably on 7 January, 1943. He had attached a 'Don't disturb' sign to his door with the result that he was only found dead in his bed on 8 January 1943.

Nikola Tesla had been born into a very dynamic era of technological development. Especially in electrical engineering, the period between 1850 and 1950 was marked by important inventions. Among the most important representatives of this period were:

- Werner von Siemens (1816 – 1892)
- Wilhelm Conrad von Röntgen (1845 – 1923)
- Thomas Alva Edison (1847 – 1931)
- Heinrich Hertz (1857 – 1894)
- Guglielmo Marconi (1874 – 1937)
- Otto Nußbaumer (1876 – 1930)

The work of three persons can be seen as having a very close connection to Nikola Tesla:

- Thomas Alva Edison, with whom he worked very closely for a time.
- Guglielmo Marconi, with whom he conducted a patent dispute for many years which was eventually settled in Tesla's favour (after his death) by the Supreme Court of the USA.
- Otto Nußbaumer, with whom he did not have any direct contact, but who managed to transmit music wirelessly for the first time ever at the Chair of Physics at the College of Technology, Graz, on 15 June 1904.

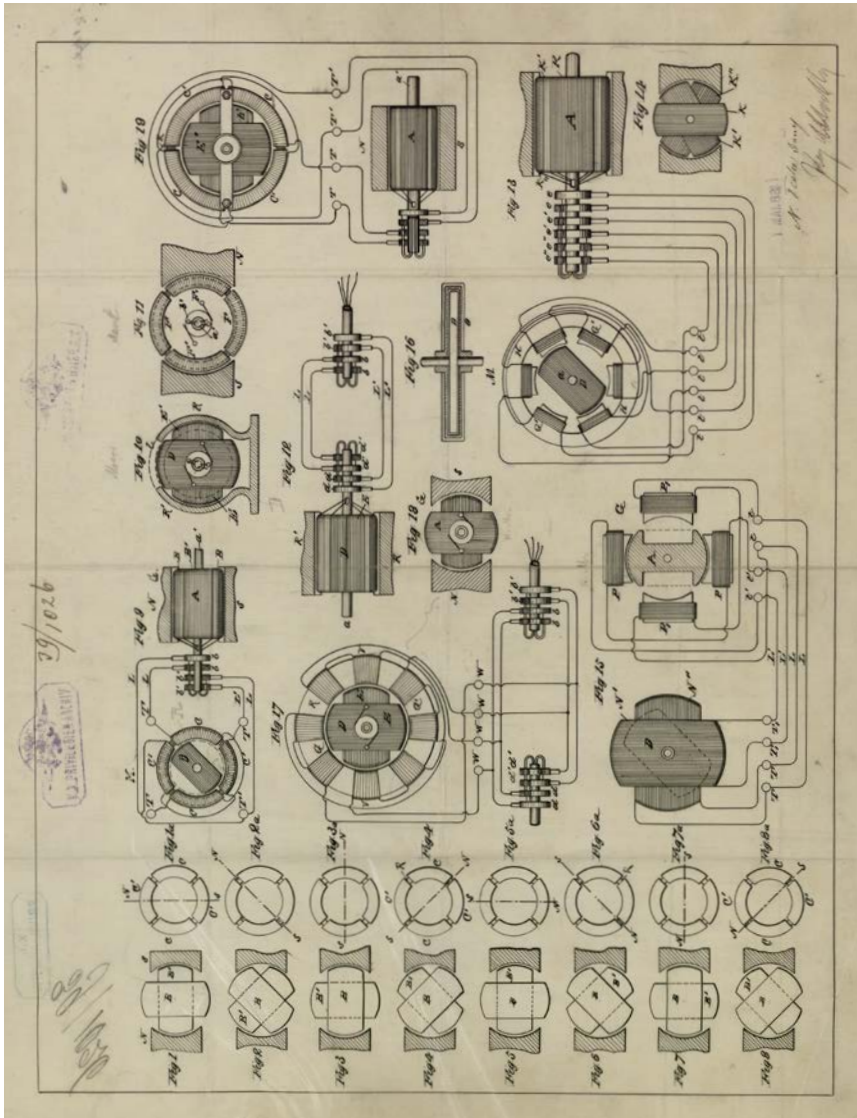

Fig.: Privilege: 'Innovations in the transmission of electrical power' (Original: data bank of privileges of the Austrian Patent Office, Vienna.)

---

**Nikola Tesla:  
Student at the Graz Tech**

At the beginning of the 1875/76 academic year, Nikola Tesla started his studies at the former Imperial and Royal College of Technology at Graz.

In his academic file, his date of birth was later corrected to 10 July 1856; his nationality is cited as 'Serb'. Smiljan is entered as his place of birth, on the military border.

In his first academic year, Nikola Tesla took his studies very seriously. He took examinations on 11 different lecture courses with a total of 46 hours. This can be described as clearly above average.

The courses in the first academic year comprised:

Subjects	Hours	Lecturer	Proven success
Mathematics I	7	Rogner	Excellent
Mathematics II	7	Alle	Excellent
Experimental physics	5	Pöschl	Excellent
Organic chemistry	5	Maly	Excellent
Inorganic chemistry	5	Maly	Excellent
Zoology	5	Grabner	Excellent
General botany incl. demonstrations	3	Leitgeb	Excellent
Demonstration Popular mechanics	2	Bartl	Excellent
French language	3	Plisnier	Excellent
Cubing of areas II	2	Rogner	Excellent
Practical arithmetic	2	Rogner	Excellent

Reflecting on this time, Nikola Tesla wrote forty years later (/10/):

'In the first year of my studies at the Joanneum I rose regularly at three o'clock in the morning and worked till eleven at night; no Sundays or holidays excepted. My success was unusual and excited the interest of the professors. Among these was Dr. Allé, who lectured on differential equations and other branches of higher mathematics and whose addresses were unforgettable intellectual treats, and Prof. Poeschl, who held the chair of Physics, theoretical and experimental. These men I always remember with a sense of gratitude.'

Nikola Tesla worked with great diligence in his second year (1876/77), too. He enrolled for a total of eleven lectures, but only completed five of them successfully. He did not take any examinations in the other subjects. One lecturer records 'no contact'.

Subjects	Hours	Lecturer	Proven success
Mathematics III	6	Alle	Excellent
Technical mathematics	5	Stark	Excellent
Analytical mathematics	2	Stark	No contact
Technical physics	3	Pöschl	Excellent
Mineralogy	3	Rumpf	-
Element of Wave theory	2	Pöschl	-
Theory of conical sections	2	Pelz	-
On congruencies of numbers	2	Rogner	Good
On selected problems of political arithmetic	3	Rogner	Good



Fig.: Johann Rogner  
(Styrian Provincial Archives).



Fig.: Moriz Allé  
(TU Graz Archive).



Fig.: Jakob Pöschl  
(Univ.-Prof. Dr. B. Koidl).

In his third year of studies (1877/78), Nikola Tesla attended ten courses. They comprised the following subjects:

Applied mathematics Mathematics III C

Theory of invariants

Theory of conical sections Analytical mechanics

General theoretical mechanics

Special theoretical mechanics

Physical geography

French language II C

English language

However, in the academic file only the following notes have been added: 'Did not contact the professor' and 'Excluded for not paying the course fees for the first semester 1877/78'.

Regarding Tesla's further development, Professor Jakob Pöschl was definitely his most important contact person among the teaching staff. Jakob Pöschl (born 1828 in Vienna, died 1907 in Graz) was full professor of physics at the Technical Academy of the Joanneum and at the College of Technology in Graz from 1855 to 1887.

Today, Nikola Tesla is primarily seen as an inventor in the field of electrical engineering. A special lecture on electrical engineering was first held at the College of Technology in Graz in the 1889/90 academic year by Albert von Ettinghausen, professor of physics.

Up until then – and thus also during Nikola Tesla's time – the subject matter of electrical engineering was dealt with in the physics lectures. A document (prepared by Josef Schaschl /9/) for the lecture on 'Technical Physics', held by Jakob Pöschl in the 1878/79 academic year, contained the following topics:

- Applied electrical science
- Applied thermodynamics
- Applied optics



In the main subject 'Applied electrical science' (containing 243 pages), the following topics were dealt with:

- Electrical telegraphy
- Electric clocks
- Electromagnetic motors
- Electrotyping
- Lightning conductor design
- Ignition methods for exploding mines under water

The documents from Josef Schaschl are testimony to the high academic level of Jakob Pöschl's lecture. Building on fundamental explanations (using galvanic elements, and electrical measuring methods), electrical telegraphy (needle telegraphy, morse telegraphy) and electromagnetic motors (Gramme machines) were dealt with. Furthermore, there were expositions of contemporaneous developments, such as the Atlantic cable and the then two-year-old telephone of Graham Bell.

Nikola Tesla valued the lectures of Professor Jakob Pöschl very highly, receiving an outstanding education in applied electrical science, which was definitely an extremely important basis for his later activities as an inventor. At the same time, he was often quite critical of the explanations of Jakob Pöschl.

In the demonstration of a Gramme machine acting as a motor, sparks and loud noises were emitted from the brushes. Nikola Tesla asserted that it must be possible to actuate the motor without the brushes. Professor Pöschl countered that this was not realistic, and concluded with a remark which can be found in Tesla's autobiography as a quotation: 'Herr Tesla may go on to achieve great things, but this will not be one of them. This would be as if a force acting in a straight direction, such as gravity, were to be converted into a force acting in a circular path. This would be comparable to a perpetuum mobile, an impossible idea.'

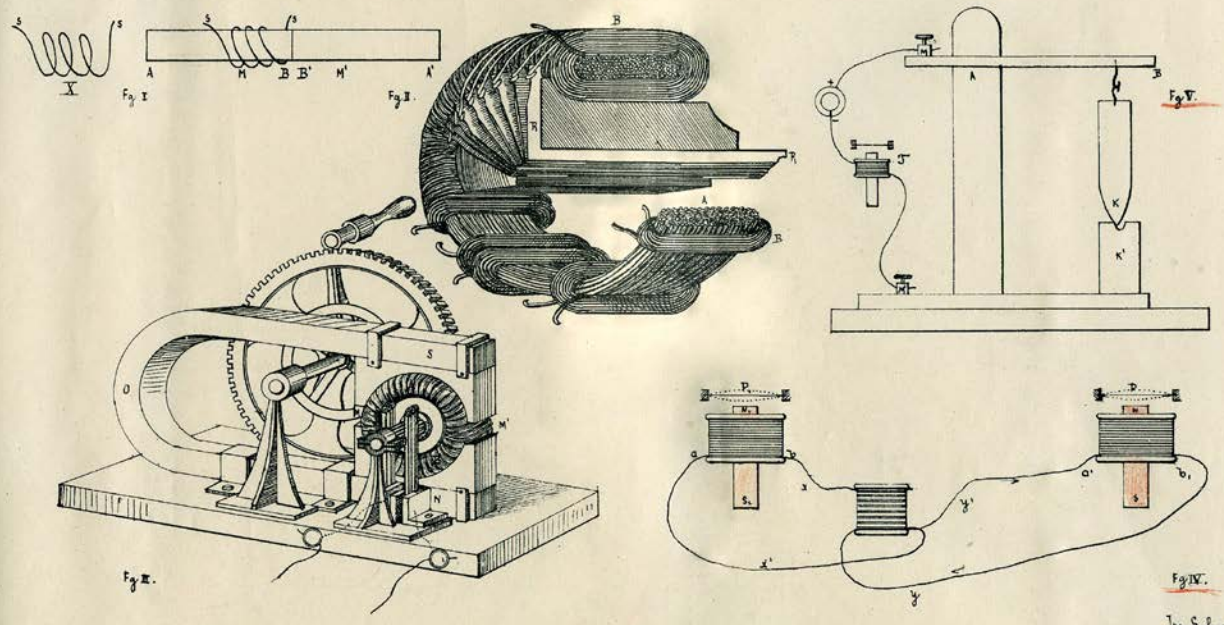

Fig. V.  
Jos. Schaschl.

Fig.: Technical physics (according to the lectures of Mr J. Pöschl, imperial and royal full professor at the Imperial and Royal College of Technology at Graz, collected and signed by Jos. Schaschl), (TU Graz Library).

Nikola Tesla's period of study at the I.R. College of Technology at Graz came to an end in the spring of 1878. Tesla had received a scholarship for his studies which had been authorised by the Imperial and Royal General Command at Agram (today's Zagreb). In the letter relating to this (dated 22 September 1876) 'to the laudable Rectorate of the Imperial and Royal College of Technology at Graz', it is stated among other things:

'A stipend of four hundred and twenty (420) guilders is granted to the teaching post candidate, Nikola Tesla, who comes from Gospić in the Lika-Otočac Border Region district, and attends the local higher education institution, and whose education is intended for the higher teaching profession, namely, in the mathematical and technical group and the French language for the duration of the specified triennium under the condition of constant, good progress in his studies to an amount in accordance with the academic laws under the obligation of carrying out a minimum of eight years service after completion of studies.'

Since Nikola Tesla had not paid the required teaching fee for the 1877-78 academic year, he was removed from the register of the College of Technology at Graz. This was communicated to the military authorities in Agram by the Rectorate in a letter dated 12 March, 1878. By return of post on 31 March, 1878, a letter asked at what point of time Tesla had drawn the stipend and what the relevant reasons were for the inadequate progress in his studies (e.g. illness).

The answer from the Rectorate on 15 April 1878 was unambiguous: Tesla had drawn the stipend up until January 1878; he had not been in hospital. Due to these circumstances, the military authorities in Agram communicated in a letter of 4 May 1878 that payment of the stipend was to be discontinued.

This marked an end to Nikola Tesla's stay at the I.R. College of Technology at Graz. Nikola Tesla, who during his stay in Graz was resident at four different addresses, namely Neugasse 10 (today's Hans-Sachs-Gasse), Attemsgasse 11, Jahngasse 5 and Heinrichstraße 11, returned home.

However, he always remained in constant contact with the Graz Tech. In the commemorative publication on the occasion of the centenary of the Joanneum (published by the Association of Former Graz Engineers in November 1911/11/), the following entry can be found (on page 182) among the members (with the number 576):

Tesla Nikola (576)  
Electrical engineer, New York, USA.

Baufache an der Technischen Hochschule in Graz, em. kaiserl. deutscher Bauführer der Reichs-Eisenbahnen in Elßaß-Lothringen; Graz, Salzamtsgasse 2. (Mitglied des Ausschusses.)

**Tengler Karl (803),**  
Ingenieur; Ried.

**Tesla Nikola (576),**  
Elektriker; New-York, Vereinigte Staaten.

**Teuchert Josef (111),**  
Inspektor und Vorstand-Stellvertreter der Maschinenabteilung der k. k. priv. Kaschau-Oberberger Bahn; Budapest, V., Rudolfskai 6.

**Tiefenbacher Ludwig (89),**  
k. k. Ober-Baurat, o. ö. Professor an der k. k. Hochschule für Bodenkultur in Wien und Honorar-Dozent an der k. k. Technischen Hochschule in Wien, niederösterreich. Landes-Eisenbahnrat, Mitglied der Kommission zur Abhaltung der II. Staatsprüfung aus dem Bau-Ingenieurfache an der k. k. Technischen Hochschule in Wien, Besitzer der kais. öst. goldenen Medaille für Wissenschaft und Kunst; Wien, XV., Mariahilferstraße 127 A.

**Till Karl (518),**  
Jur.-Dr. und Ingenieur, Direktions-Sekretär und Prokurist der Königshofer Zementfabrik, Wien, I., Bauernmarkt 13; Wien, XX./2, Engerthstraße 150.

**Tiz Eduard (691),**  
Maschinen-Oberkommissär, Heizhaus-Chef der k. k. priv. Südbahn; Mürzzuschlag.

**Tökei Karl (561),**  
Maschinen-Fabrikdirektor a. D., Präses-Stellvertreter der Kommission zur Abhaltung der II. Staatsprüfung aus dem Maschinenbaufache an der k. k. Technischen Hochschule in Graz, Besitzer des Schiedsgerichtes der Arbeiter-Unfallversicherungs-Anstalt für Steiermark und Kärnten in Graz; Graz, Mozartgasse 4.

**Toucouart Guido, Edler v. (124),**  
k. k. Hofrat des k. k. Ministeriums für öffentliche Arbeiten, Chef des technischen Dienstes und Schiffahrts-Inspektor der internationalen Pruth-Kommission, Ritter des Ordens der Eisernen Krone III. Klasse und des Franz Josef-Ordens, Kommandeur des kaiserl. russischen Stanislaus-Ordens und des königl. rum. Kronen-Ordens, Offizier des königl. rumän. Ordens „Stern von

Fig.: Extract from the register of members of the Association of Former Graz Engineers (November 1911), TU Graz Archive.

---

Nikola Tesla:  
Honorary doctor of  
technical sciences

Nikola Tesla did thus not complete his studies at the I. R. College of Technology. In his later journey through life, however, Tesla accomplished such monumental achievements that the title and rank of an honorary doctor of technical sciences was bestowed on the former student 60 years after his studies.

Up to that point Nikola Tesla had received many awards. Thus, appropriate tribute was envisaged at the Graz Tech (most probably on the occasion of his 80th birthday in 1936). Apart from that, at this time (from 1935 to 1937), the College of Technology at Graz had been merged with the Institute of Mining in Leoben to create the Graz-Leoben College of Technology and Mining.

For this reason it is stated in the document drawn up on 23 January 1937:

‘By the power of the rights vested in the College of Technology, by way of a unanimous resolution of the Professorial Council and with the authorisation of the federal government, the Graz-Leoben College of Technology and Mining, on behalf of Graz under the Rectorate of Dr. techn. Architekt Friedrich Zotter, o.ö. Professor of Architecture, confers on Nikola Tesla, Dr. techn. e. h. etz., the title and the rank of a honorary doctor of technical sciences and all the rights associated with it in recognition of his outstanding merit in the development of polyphase current machines and high-frequency technology. Awarded in Graz on 23 January 1937.’

The academic officials on the occasion of the bestowal of this honour were:

- Rector: Dr. techn. Architekt Friedrich Zotter,  
Professor of Architecture
- Dean of the Faculty of Applied Mathematics and Physics:  
Dr. phil. Bernhard Baule, Professor of Mathematics
- as properly appointed promoter:  
Dr. techn. Karl Federhofer, Professor of Mechanics.

In response to a petition from Professor Dr. Fritz Kohlrausch, the Faculty of Applied Mathematics and Physics passed a unanimous resolution on 30 October 1936 to go ahead with the honorary doctoral graduation. Dean Professor Dr. Bernhard wrote the following report:

‘Rector, as we passed review on the occasion of the 125th anniversary of the foundation day of the Joanneum and allowed the history of our College of Technology with all its teaching staff and students to pass in front of our eyes, our attention was caught by the name of one man who, exactly 60

years ago, came from a small Croatian town and sought out the College of Technology at Graz in order to gain from it the intellectual tools for his physical-technical creativity. His name was Nikola Tesla. Tesla attended our College of Technology from 1875 to 1878. He then, as is reported, ran out of funds and had to leave the Institute without having completed his degree. But what Tesla learnt in those few semesters of his studies in Graz was sufficient to establish his career as an electrical engineer in such a fruitful and successful way. On the basis of the knowledge acquired in Graz, Tesla found employment in a telephone company in Budapest, and he was there able to continue his investigations which he had begun here at the Institute of Physics on the construction of an electric motor using a rotating electromagnet field and without commutator and brushes. But he did not stay long in Budapest. He was driven yonder, towards the west, where for the inventor genius that he was, there appeared more fertile ground than here in central Europe. In 1883 we see Tesla in Strasbourg, and one year later he has arrived in the land of unlimited opportunity – America. And before one full decade since the commencement of his studies at Graz had elapsed, he was able to reap the rich fruits of his technical creativity and ability. In 1887, the fundamental patents for the construction of polyphase alternating current machines were granted to him. In other words, those machines which conquered the world in a fast triumphal procession and which almost no power station does without today.

'It is typical of Tesla's inventive spirit and drive for research that no sooner had he considered the problems in the field of engine construction to be solved – those which he had entertained and which had been a leading force in his thoughts and creativity – than he directed his keen enquiring mind to another place and in a completely different direction, and drove it on with tremendous perspicacity into a new, completely unknown land – into the land of high-frequency technology. The name of Tesla is today inextricably linked with this vast, rich and beautiful field of technical physics – and will be for ever, as is the name Columbus with America.

'The Graz College of Technology had good reason to be proud of its former student and to remember him when any commemoration day gives occasion to leaf through the pages in the annals of the Institute. But on such occasions we commemorate Tesla with special joy since we know that for the duration of the six decades and the six thousand kilometres which separate him from the Graz College of Technology today, he still felt the intellectual connection with his and our Institute, and has remained aware of it throughout the decades.

'The Faculty of Applied Mathematics and Physics with all its students, young and old alike, made a request to give visible expression to this intellectual affinity to the College by nominating Nikola Tesla, the senior of our older student body, as a honorary doctor of our College in acknowledgement of his outstanding achievements in the field of applied physics. The Professorial Council was delighted to agree to this request and thus I, as the current Dean of the Faculty of Applied Mathematics and Physics, have the honour and the pleasure to request the Rector to allow Nikola Tesla to be awarded an honorary doctoral degree of our university.'

Nikola Tesla was unable to appear in person in Graz to receive the document. According to his [Tesla's] desire, Engineer Slavko Boksan from Belgrade, along with a delegation from the Tesla Institute, represented him.

**Engineer Slavko Boksan held the following speech of thanks:**

'Rector, deans, honoured professors, ladies and gentlemen!

'Today's festive conferment of a honorary doctorate on Nikola Tesla by the Graz-Leoben College of Technology and Mining means a special honour and joy to Tesla since it comes as a recognition of the great achievements in the fields of engineering of that university at which he received his initial ideas for his later great deeds, and awoke in him memories of the wonderful time of his studies which he so happily spent 60 years ago.

'It is no accident that Tesla studied at the College of Technology at Graz. Tesla's father had given his word to his sick son to send him to the best higher education institute in Europe. The general opinion at the time was that the College of technology at Graz was the best, and he sent his convalescent son to Graz at the end of 1875 to fulfil the most fervent wish of the young Nikola – to become an engineer. Although Tesla had rather weak health in his first year of studies, he worked very assiduously and quickly became known as the

most diligent and best student. He did not miss a single lecture in his first year and passed all his examinations with distinction. In his second year, however, he was not so exemplary. He went out more often with his friends, and spent a lot of his time in coffee houses, missing the occasional lecture. According to a colleague of Tesla's, the aged professor in Sarajevo, Kosta Kuliši , who lodged for a time in the same rooms as Tesla in Attemsgasse in Graz, Tesla often stayed out late in the cafés until after midnight, playing billiards and chess with a passion. Just as passionately, he visited the library and the physics laboratory. Pöschl's experiments with the Gramme machine were of great interest to him, and he had occupied himself since 1877 with the problem of an electric motor without commutator and brushes, something which he often discussed with his professor.

'Through this, Pöschl contributed to Tesla's discovery of the rotating magnetic field and three-phase system in 1882, and thus to the foundations of three-phase power transmission. In any case, I think it necessary to highlight in particular Pöschl's merits, for his experiments and his trust in Tesla's capabilities crucially influenced Tesla's interest in the alternating current motor.



Fig.: Friedrich Zotter, Rector  
(photo: H. Tezak).



Fig.: Bernhard Baule, Dean  
(photo: H. Tezak).



Fig.: Karl Federhofer, Promoter  
(photo: H. Tezak).

'Tesla's later struggle with the three-phase system is generally well known today. Along with his revolutionary discoveries, Tesla left Budapest for Paris in 1882, and from there he went to Strasbourg the next year and in 1884 to America, where he registered the basic three-phase current patents in 1887 and ushered in a new epoch in electrical engineering. So great was the aversion of the engineers and scientists of that time to alternating current and so great was the preference and the bias in favour of direct current that Tesla had to fight for more than five years to get funds to ensure victory for his new system. It is also no wonder, for Marcel Deprez carried out big experiments in 1886 to show that the problem of power transmission could only be solved using direct current. And what was the result? Five direct-current 1000-volt dynamos connected in series and a total of 200kW had to be used to transmit barely half of this energy over a distance of 15 km.

'This appears almost improbable today because now we transmit millions of kilowatts across hundreds and even thousands of kilometres – but using Tesla's alternating current, which allows bigger machine units to be built and higher voltages to be run. Today, large electrical factories have no problems building enormous generators for 100,000 or more kilowatts and huge transformers for 220,000 volts or even 400,000 volts. Whereas at the end of the last century, according to the well-known engineer E. Egger in the E. u. M. of 1893, New York was supplied with electrical energy in 1950 by small electrical centres distributed in various parts of the city, today it is possible to cover an incomparably greater demand with a single centre.

'Bearing these figures in mind, the importance of the three-phase system and the achievements of Tesla become clear. Equally important are the results which have been achieved in the field of high frequency and radio technology over the decades, whose foundations were laid by Tesla's research and discoveries.

'The Graz-Leoben College of Technology and Mining played a decisive role in all these results because its former student made them possible.

'Rector, Allow me to offer you and the Professorial Council my warmest thanks as Tesla's representative. By conferring a doctorate on Tesla today, you have accorded him a great honour and given him a special pleasure. I know that he is present here at this time in his thoughts, and that he is thinking of the wonderful time as he studied at your university and spent time in this pleasant city. I therefore ask you once again, on behalf of Tesla, to accept my most sincere thanks.'

Two other persons were awarded honorary doctorates in technical sciences at the same time as Tesla on 23 January 1937. They were:

- Hofrat em.o.ö. Professor Friedrich Emich,  
Dr. phil. h.c., Dr. Ing. e.h.
- Dr. techn. Emil Flatz,  
director and member of the management board of Humboldt-Deutz-Motoren AG.

On the occasion of this academic ceremony, all those present were invited to a festive dinner. The order of courses is known to posterity:

Mayonnaise and aspic  
Hunter's fillet of venison  
Styrian poularde  
Mixed salad  
Chestnut purée and cream  
Mokka

During the banquet, Dean Prof. Dr. Bernhard Baule brought the following letter of thanks from Nikola Tesla to the attention of those present:

Telegram from Nikola Tesla to the Rector of the Graz-Leoben College of Technology and Mining on the occasion of his honorary doctoral graduation on 23 January 1937.

I cannot adequately express my regret of how much I miss the opportunity of making new friendships and personally accepting the document of honour which I esteem so highly from the College of Technology at which I, under the guidance of extraordinarily authoritative and paternally inclined teachers, lessened my tremendous ignorance through clear concepts. I owe these high-minded men a considerable share of my life's work; namely, to the captivating Doctor Allé, who devoted many private lessons to me to illuminate my mathematical knowledge and to practise it by way of profoundly thought-out

exercises. And also to Messrs. Rogner, who befriended me and taught me, and Pöschl, in whose masterfully conducted experiments I found great stimulation and fruitful knowledge. The other members of the Professorial Council unhesitatingly encouraged me and they, too, are alive in my grateful memory. Despite the sixty years that have elapsed, they all appear before my eyes undimmed as though in person. The old spirit still dwells in your halls of learning. May your eminent, time-honoured and unsurpassed institute continue its work in ever-larger circles of activity throughout the coming centuries for progress and the spread of science and for the benefit of all humanity.

Fig.: Nikola Tesla's telegram of thanks on the occasion of his honorary doctoral graduation in 1937 (TU Graz Archive).

Nikola Tesla

Diensthilfe Angaben:	Satzung: <b>Telegramm</b> Eing.-Nr. = nlt = der rektor der technischen u montanistischen hochschule Grazleoben rehbauerstrasse 12 graz	Die Telegraphenverwaltung übernimmt hinsichtlich der ihr zur Beförderung oder Bestellung übergebenen Telegramme keine wie immer geartete Verantwortung.
Aufgenommen von	newyork 22 78/76 11 nftviawunion mci viaradio	
auf Fg. Nr.	Die obigen Angaben bedeuten: 1. den Namen des Aufgabebesetztes, 2. die Aufgabennummer, 3. die Wortzahl (auch in Bruchform), 4. den Montagstag, 5. die Aufgabebesetz.	
am 193 um Uhr M.	= ich wuensche dem hochgeehrten professorenkollegium wie ihnen selbst meinen herzlichsten dank fuer die seltene und vielgeschaeetzte ehre auszusprechen und sie versichern dass ich nur zu gerne die gelegenheit benuetzen wuerde meinen gefuehlen persoentlich ausdrueck zu geben wenn es moeglich waere . ich habe jedoch boksen ersucht mich zu vertreten und sie werden von ihm hoeren mit erneuertem danke ihr sehr ergebener nikola tesla +	

**K**raft des den Technischen Hochschulen erteilten Rechtes verleiht  
über einstimmigen Beschluß des Professorenkollegiums und mit  
Ermächtigung der Bundesregierung die Technische und Monta-  
nistische Hochschule Graz-Leoben zu Graz unter dem Rektorate von

**Dr. techn. Architekt Friedrich Jotter**  
o ö Professor für Baukunst

**Herrn Ingenieur**  
**Nikola Tesla**  
Dr. techn. e. h. et z.

in Anerkennung seiner überragenden Verdienste um die Entwick-  
lung der Mehrphasenstrom-Maschinen- und der Hochfrequenz-Technik

den Titel und die Würde eines

**Doktors der technischen Wissenschaften**  
ehrenhalber

samt allen damit verbundenen Rechten-

Urkund dessen wurde dieses Diplom ausgefertigt  
Gegeben zu Graz, am 25. Jänner 1937-

Der ordnungsgemäß  
bestellte Promotor

Der  
Rektor

Der Dekan der Fakultät  
für angewandte Mathe-  
matik und Physik.

*Jotter*

*Dauk*

Fig.: Deed of the conferment  
of the title and rank of a  
honorary doctor of technical  
sciences on Nikola Tesla  
(Graz 1937).

Fig.: Entry in the  
doctoral graduation  
book of the Graz Tech  
(TU Graz Archive).

71

Herr D. Ing. Nikola Tesla,  
aus Smiljivan, Serbien  
wurde am 23. Januar 1937 zum

**Doktor der technischen Wissenschaften** *e.h.*

promoviert.

[Signature]  
dz. Rektor.

[Signature]  
dz. Dekan.

[Signature]  
Promotor.

Kandidat.  
für D. Ing. t.e. Nikola Tesla  
Ing. J. Bokšan

It is particularly at a university of technology, where technological progress has always in the past strongly shaped the work of the university, and change still does shape it in the broadest sense, that the area of conflict between tradition, on the one hand, and innovation, on the other, is especially challenging, but also fruitful.

Evidently, it depends on the mind in which tradition and innovation is cultivated. It depends on the persons as actors.

Graz University of Technology – Erzherzog-Johann-Universität – has always been characterised by a culture that we would today call the ‘spirit of Archduke Johann’.

The university as scientific community, as a community of students and faculty, is primarily shaped by the persons associated with it. Nikola Tesla doubtlessly belongs to the great personalities who have been involved in the community at the Graz Tech.

This special relationship is expressed today and will be in the future in three ways:

- Since 2006, there has been a plaque at the Joanneum (the original location of today’s University of Technology) commemorating the student Nikola Tesla.
- Also, the large experimental hall at Graz University of Technology’s Institute of High Voltage Engineering and System Performance was renamed the Nikola Tesla Laboratory in 2006.
- And finally, the Nikola Tesla Medal has been awarded for special inventive achievements at Graz University of Technology since 2015.

Nikola Tesla and the Graz Tech can thus be seen to represent a constant striving in academic research and teaching to make the best possible contributions to solving the problems facing human society. This was true for the time when Nikola Tesla was a student and honorary doctor, and it is equally true today and for the future.

Fig.: Nikola Tesla Medal of  
Graz University of Technology  
(photo: D. Herbst).

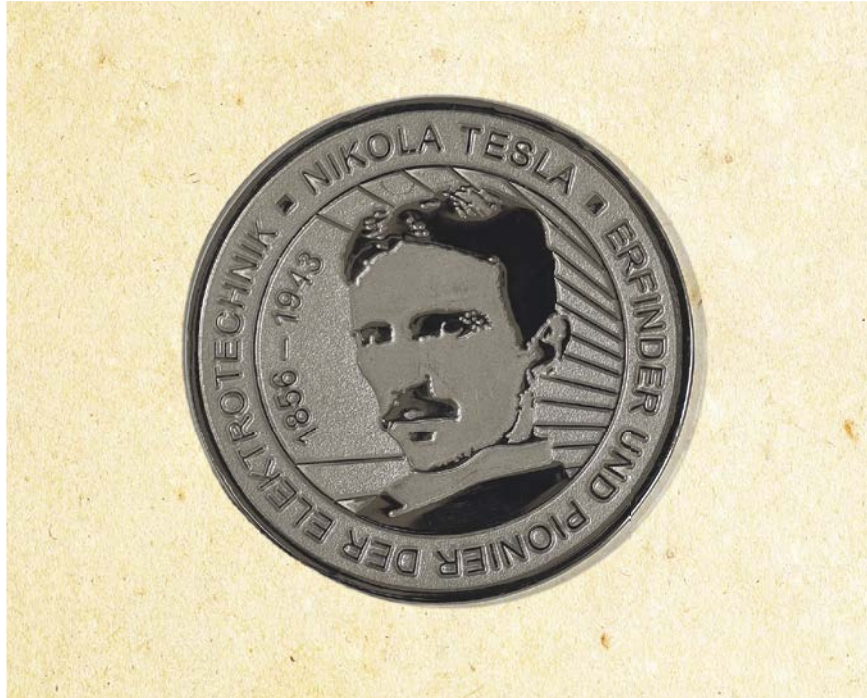

- References**
- /1/ CHENEY, Margaret: Tesla – Man Out of Time, Englewood Cliffs 1981 (deutsch: Nikola Tesla – Erfinder, Magier, Prophet, Düsseldorf 1997, 3. Aufl.).
  - /2/ K.K. TECHNISCHE HOCHSCHULE: Zur Feier der Eröffnung des Neubaues der k.k. Technischen Hochschule in Graz am 12. Dezember 1888, Graz 1888.
  - /3/ KERNBAUER, Alois: Richard Zsigmondy – Assistent, Privatdozent, Nobelpreisträger, in: Wohinz Josef W. (Hg.): Die Technik in Graz – Vom Joanneum zur Erzherzog-Johann-Universität, Graz-Wien-Köln 2002, S. 157 – 165.
  - /4/ MAGENSCHAB, Hans: Erzherzog Johann – Habsburgs grüner Rebell, Graz-Wien-Köln 1981.
  - /5/ NIKOLA TESLA MUSEUM (Hg.): Nikola Tesla – Lectures, Patents, Articles, Beograd 1956.

/6/ NIKOLA TESLA MUSEUM (Hg.): Tribute to Nikola Tesla, Presented in Articles, Letters, Documents, Beograd 1961.

/7/ PALLA, R.: Der Mann, der das 20. Jahrhundert erfand, in: Der Standard, 11. Jänner 1992.

/8/ PICHLER, Franz und ASENBAUM, Augustinus: Zum Studium von Nikolaus Tesla in Graz und Prag, in: PLUS LUCIS, Mitteilungsblatt des Vereins zur Förderung des physikalischen und chemischen Unterrichts, Wien, Heft 2/96, S. 9 – 13.

/9/ SCHASCHL, Josef: Technische Physik (nach den Vorträgen des Herrn J. Pöschl, k.k. ö.o. Professor an der k.k. Technischen Hochschule in Graz, 1878/79).

/10/ TESLA, Nikola: Some personal recollections (Scientific American, June 5, 1915), in: NIKOLA TESLA MUSEUM (Hg.): Nikola Tesla – Lectures, Patents, Articles, Beograd 1956, S. 195 – 199.

/11/ Verband ehemaliger Grazer Techniker (Hg.): Festschrift zur Jahrhundertfeier des Joanneums, Graz 1911.

/12/ WOHINZ, Josef W. (Hg.): Die Technik in Graz – Vom Joanneum zur Erzherzog-Johann-Universität, Graz-Wien-Köln, 2002

Insbesondere: Hutten, Helmut: Nikola Tesla – Technik – Student, Jahrhundert – Erfinder, S. 127 – 146.



Nikola Tesla –  
Visionary and Inventor

Contributions to scientific  
and industrial development

by Uwe Schichler

With his visionary ideas and inventions, Tesla substantially shaped electrical engineering for decades. In TU Graz's Faculty of Electrical Engineering and Information Technology of today, Tesla's discoveries are being passed on to the students and most of the research deals with technological applications and implementations which can be attributed to Tesla. A great importance is thus attached to the Nikola Tesla Laboratory, which belongs to the Institute of High Voltage Engineering and System Performance, since Tesla's most important experiments are regularly reproduced in this unique high-voltage testing laboratory, thus expressing the deep connection of Graz University of Technology to its former student, who was awarded a honorary doctorate in 1937. The high-voltage testing laboratory was named after Tesla in 2006 on the occasion of the 150th anniversary of his birth.

---

Development of  
electrical engineering  
from 1850 to 1950

The development of electrical engineering from 1850 to 1950 was driven forward by the achievements of several big figures. The scientists, inventors and entrepreneurs subsequently described here – in addition to Tesla – were responsible for a substantial part of the scientific and industrial development of the time.

- Werner von Siemens (1816 – 1892): German inventor and industrialist who developed the first electrical generator in 1866 on the basis of the electrodynamic principle which he had discovered and is regarded as the pioneer of electrical engineering.
- James Clerk Maxwell (1821 – 1879): Scottish physicist who formulated the mathematical foundations of electricity and magnetism, which were first published as Maxwell's equations in 1864.
- George Westinghouse (1846 – 1914): American engineer, inventor and industrial magnate. He acquired Tesla's patents and marketed them together with his own ideas. In this way he helped the transmission of electrical energy using polyphase alternating current to achieve a worldwide breakthrough.
- Thomas Alva Edison (1847 – 1931): American entrepreneur and inventor in the field of electricity and electrical engineering. His direct current technology electrified the lighting systems of a number of cities and drove motors. In 1882, New York's first central direct current power station was started up, and he conducted the so-called War of Currents against Tesla and Westinghouse over many years.

- Heinrich Rudolf Hertz (1857 – 1894): German physicist who in 1886 became the first person to prove and produce electromagnetic waves. He thus provided the basis for the development of wireless telegraphy and the radio.
- Guglielmo Marconi (1874 – 1937): An Italian pioneer of telegraphy who managed to carry out a wireless connection from Dover to Wimereux across the English Channel in 1899. In 1902, the first transatlantic wireless transmission was carried out, and in 1909, Marconi was awarded the Nobel Prize for physics.

Tesla was granted more than 110 patents in America alone. He was awarded twelve honorary doctorates and is only one of twenty four scientists worldwide to have been given the honour of having his name used as a scientific unit: Volt, Ampere, Ohm, Hertz ...and Tesla /1/. Since 1960, the 'Tesla' unit of measurement has designated the magnetic flux density in recognition of his outstanding scientific ideas and achievements. Associated with the natural magnetic field of the Earth, Tesla is thus immortalised all over the world.

---

The problem of  
the commutator

Tesla's intensive research activities were triggered off by a disputation with physics professor Jakob Pöschl during a demonstration of a Gramme machine at the College of Technology in 1878. Prof. Pöschl had snubbed Tesla by calling a suggestion of his an impossible idea. Tesla had correctly identified the stream of sparks emanating from the two brushes on the commutator of the Gramme machine – necessary for direct current operation – as a source of great loss. His suggestion to Professor Pöschl was to dismantle the commutator and the sliding contact and to run the machine using alternating current /2/.

In 1882, as the leading engineer of a telegraph company in Budapest, Tesla developed the idea of a rotating magnetic field that could drive a commutator-free motor. The genius of this idea was to produce the rotating magnetic field by superimposing several out-of-phase alternating currents. The rotating magnetic field he invented brought his endeavours of many years to develop a powerful commutator-free alternating current motor to a successful close. Tesla built one of his first models of a motor driven by polyphase alternating current in 1893.

---

The rotating magnetic field:  
Polyphase alternating  
current system

After a short period as a direct employee of Thomas Alva Edison in New York, Tesla founded the Tesla Electric Company with help from financial backers in 1887. Here, he continued his own research and realised his ideas. As a result, he filed a total of seven patents at the New York patent office in October 1887, and these were granted to him in May 1888. These patents described his discovery of the rotating magnetic field and, among other things, comprised an asynchronous (induction) machine, a synchronous machine, a polyphase transformer and energy transmission using polyphase alternating current /2/.

In this way, a scientific basis had been created for simple conversion of electrical energy and for the economical transport of energy over large distances using high voltages. Tesla's alternating current system triggered off a huge demand in the worldwide use of electricity at the end of the 19th century. His patented inventions made it possible to produce electrical energy, transport it and, above all, to convert it everywhere into mechanical power.

---

The Niagara Falls  
power station:  
Direct current or  
alternating current?

By means of the direct-current motor developed by Antonio Pacinotti in 1860, it became possible to produce mechanical force for industrial use. The first electrical transmissions using direct-current motors were presented to the public for the first time at the world exhibitions in Vienna in 1873 and in Philadelphia in 1876.

Thomas Alva Edison developed the first direct-current network in the USA, and the first power station to produce electricity was started up in Pearl Street, New York, in 1882. In the same year, Edison was able to establish the direct-current system as an overall concept for production, transmission and distribution in London. At that time, direct current was used in particular for electrical lighting installations /2/.

Due to technical problems with the direct current network, direct-current motors were only used for special machinery in large industrial companies. Companies involved in mass production did without this new form of actuation. As for alternating current, which emerged in these years, only electrical lighting installations were connected to the AC network since there were initially no powerful and reliable AC motors available.

It should be remembered that around 1880, electrical energy and electric motors had to compete against the already existing and well-established sources of power and energy of the time, such as steam engines and pressurised, hot-air and gas engines. Gas networks for light and power, which were already in place in many towns, delayed electrification in part for many years. Moreover, operation and maintenance of the novel electric motors led to high operating costs due to high personnel costs. Which system should finally establish itself was dependent on the economic interests of industry, political interests of the city and the demands of special industrial applications /3/.

To develop his alternating-current motor, Tesla had to invent a completely new electrical system. To implement his ideas, he moved from Budapest to the Continental Edison Company in Paris in 1882. At Strasbourg in 1883, he managed to make the first working alternating-current motor, although this event was met with little attention. In 1884, Tesla accepted an offer to work directly with Edison in New York.

At the beginning, Tesla and Edison worked together very successfully. Tesla improved Edison's dynamos but was cheated out of some money by Edison in the end, since he reneged on a promised bonus payment in 1885. After one year, their working relationship was ended. Tesla and Edison were two completely different characters and preferred two different electricity systems. Tesla pursued his ideas of AC as being the superior technology of the future, while Edison favoured the DC system. The essential disadvantage of the DC system was recognised by Tesla very clearly. DC for supplying lighting systems could not be transported over long distances since it was impossible to produce the necessary high voltages. Hence Edison was forced to build his DC power stations at distances no further than 3 km away.

With the help of financiers Charles Peck and Alfred Brown, Tesla was able to found the Tesla Electric Company in New York in the spring of 1887. He convinced both of them with a simple demonstration by rotating a metallic egg and making it stand on its end using an electrical rotating field. In the Tesla Electric Company, Nicola Tesla could dedicate himself to optimising his AC motor and further develop the polyphase AC system in his own laboratory in New York.

# Tesla's Egg of Columbus

## How Tesla Performed the Feat of Columbus Without Cracking the Egg

**P**ROBABLY one of the most far-reaching and revolutionary discoveries made by Mr. Tesla is the so-called *rotating magnetic field*. This is a new and wonderful manifestation of force—a magnetic cyclone—producing striking

with any speed desired. Long ago, when Tesla was still a student, he conceived the idea of the rotating magnetic field and this remarkable principle is embodied in his famous *induction motor* and system of transmission of power now in universal use.

In this issue of the *ELECTRICAL EXPERIMENTER* Mr. Tesla gives a remarkable account of his early efforts and trials as an inventor and of his final success. Unlike other technical advances arrived at thru the usual hit and miss methods and hap-

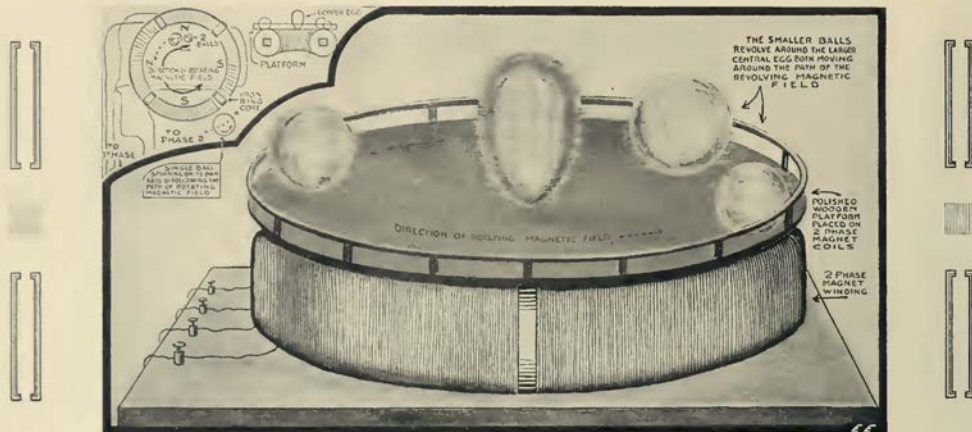

Fig. 2. Illustrating the Polyphase Coil and Rotating Magnetic Field Which Caused Copper Eggs to Spin. Fig. 3. Insert: Detail of Coil Apparatus Showing Coil Connections to Different Phases.

Fig.: Tesla's design for the Egg of Columbus, around 1887 (Electrical Experimenter 6, March 1919, p.774).

(No Model.)

4 Sheets—Sheet 1.

N. TESLA.

ELECTRO MAGNETIC MOTOR.

No. 381,968.

Patented May 1, 1888.

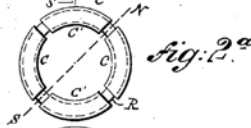
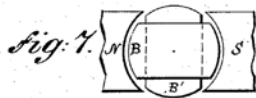
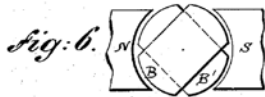
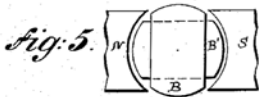
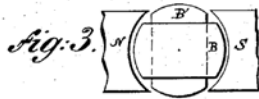
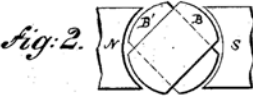

WITNESSES:

Frank E. Hartley  
Frank B. Murphy

INVENTOR.

Nikola Tesla,  
BY  
Duncan, Curtis & Page  
ATTORNEYS.

Fig.: Tesla's electromagnetic motor (mode of action of the electromagnetic rotary field), US Patent 381,968 (Google patents).

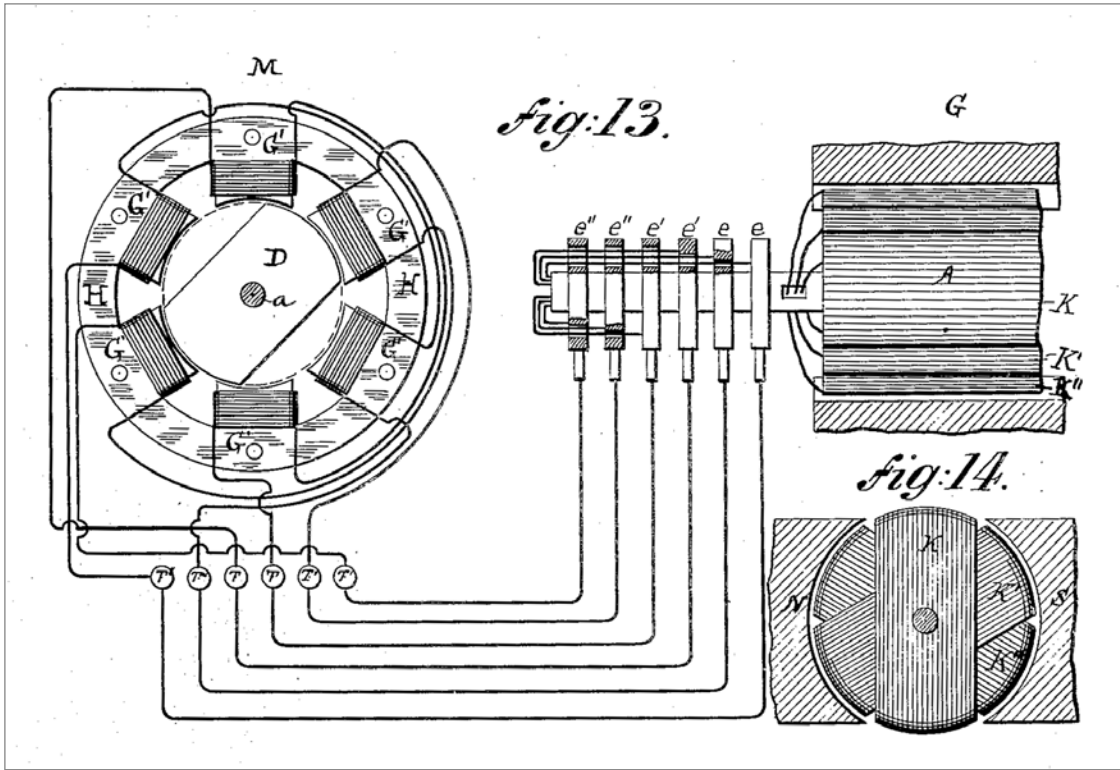

Fig.: Generator with three different alternating currents and their connections to the motor, US Patent 381,968 (Google patents).

With this, Tesla realised the requirements of a practical system of transmitting electrical power using a guaranteed and consistent motor speed at any loads within the normal work boundaries without using an auxiliary generator /3/. Motor and generator ran synchronously and the direct effect of the electricity ensured great performance capability as neither the motor nor generator were equipped with commutators. The big advantage lay in the uncomplicated and economical mechanical construction. Tesla's electrical AC machines were easy to operate and regulate, and offered diminished risk of injury and damage to persons.

Scientist and physics professor William Anthony gave his attention to Tesla's discoveries and examined two of the developed motors. Thereupon, Antony urged the 32-year old Tesla who was almost unknown in specialist circles to present his discoveries to the public and to hold a lecture in front of a specialist public. On 16 May 1888, Nicola Tesla held his highly respected lecture entitled 'A new system of alternating current motors and transformers' at the American Institute of Electrical Engineers (AIEE) in New York. Tesla showed diagrams from his patents concerning his discoveries of the rotary magnetic field and the machines based on it to help explain it to the public. In the discussion, Anthony confirmed the high efficiency of Tesla's polyphase motors.

Tesla's lecture at the AIEE was published in important technology journals and his polyphase motor heralded as a significant advance. This represented a breakthrough for Tesla's discoveries.

His work captured the interest of industrial magnate George Westinghouse from Pittsburgh. With the help of his engineers, he recognised the future importance of Tesla's new polyphase system, and that it enabled electricity to be transmitted over great distances with very little loss. Above all, not only houses could be electrically illuminated, but also industrial companies could be supplied with electrical energy for machines. A contract concluded between Westinghouse and Tesla in July 1888 and the acquisition of the patents specified in it by Westinghouse sealed the future collaboration between entrepreneurial capital and human intellect for the nationwide deployment of electrical energy in the United States of America

The electrical engineering industry of the USA played an important role in the construction of an economical and powerful electricity system at that time. One of the leading electrical engineering companies, the Westinghouse Company, along with its advisor Tesla, developed a functioning polyphase current system and introduced it to the market. Commercial success was initially hampered by the fact that a large number of industrial branches were already being supplied with DC, and large-scale DC power stations had been and were being built. This circumstance complicated and delayed the overall conversion to alternating current. Triggered off by the more than 40 patents which had been granted to Tesla up to 1891, an economic battle got under way between the proponents of the DC and AC systems.

In particular, the Edison Company and the Thomson-Houston Electric Company – both merged to form General Electric in 1892 – offered fierce resistance against alternating current in a one-sided, dirty propaganda war /3/. This occurred against their better judgment for Edison knew that only AC can be transformed and that electrical energy can only be transmitted over great distances using very high voltages at low loss.

Tesla designed AC generators, AC motors and transformers for the Westinghouse Company, which were mass produced and in 1891 also used in the mines of Colorado. Despite many years of bad press for AC, George Westinghouse and Nicola Tesla celebrated the final triumph over DC at the Chicago World Fair in 1893. There was a public comparison test to find out whether direct current or alternating current should be used to power the first all-electric world exhibition. This was impressively won by the Westinghouse Company due to the work of Tesla. Tesla introduced a two-phase induction motor with a capacity of some 220 kW while a generator produced electricity at the frequency of 30 Hz adapted to the motor.

Another prestige project in the War of the Currents between direct current and alternating current was the use of the Niagara Falls for electricity generation and supply to the city of Buffalo some 32 km away. After intensive discussions about the available technical solutions, those responsible decided in favour of Tesla's polyphase alternating current system. In October 1893, the Niagara Commission awarded the Westinghouse Company the contract to develop a hydro-electric power station to utilise the energy of Niagara Falls using the alternating current system.

A crucial factor in the decision was the first successful electricity transmission across a 176-km overhead power line in Germany. Building on an idea of Tesla's, in 1891 Oskar von Miller managed to step-up an alternating current of 55 volts to 15,000 volts and to conduct it from Lauffen am Neckar to Frankfurt am Main. George Westinghouse used the practical experience of Miller to plan and build his Niagara Falls power station. The Westinghouse Company developed the biggest and, at 5000 HP, the most powerful two-phase AC generators of that time for the production of electricity at 25 Hz. The energy produced by the power station was stepped up to 22,000 volts with transformers and transported to Buffalo over a high-voltage line made by the General Electric company [3]. The power station went into operation in 1895 with three generators and an output of 11 MW and supplied power for machinery and lighting at Buffalo over a 42-km overhead power line in November 1896. The Niagara Falls power station was later expanded by seven more generators by the Westinghouse Company, thus increasing its capacity to some 37 MW.



Fig.: Power station project Niagara Falls (Wikimedia Commons, public domain).

Fig.: Niagara Falls Power Company congratulates Nikola Tesla on his 75th birthday, 10 July 1931. (Nikola Tesla Museum, Belgrad)

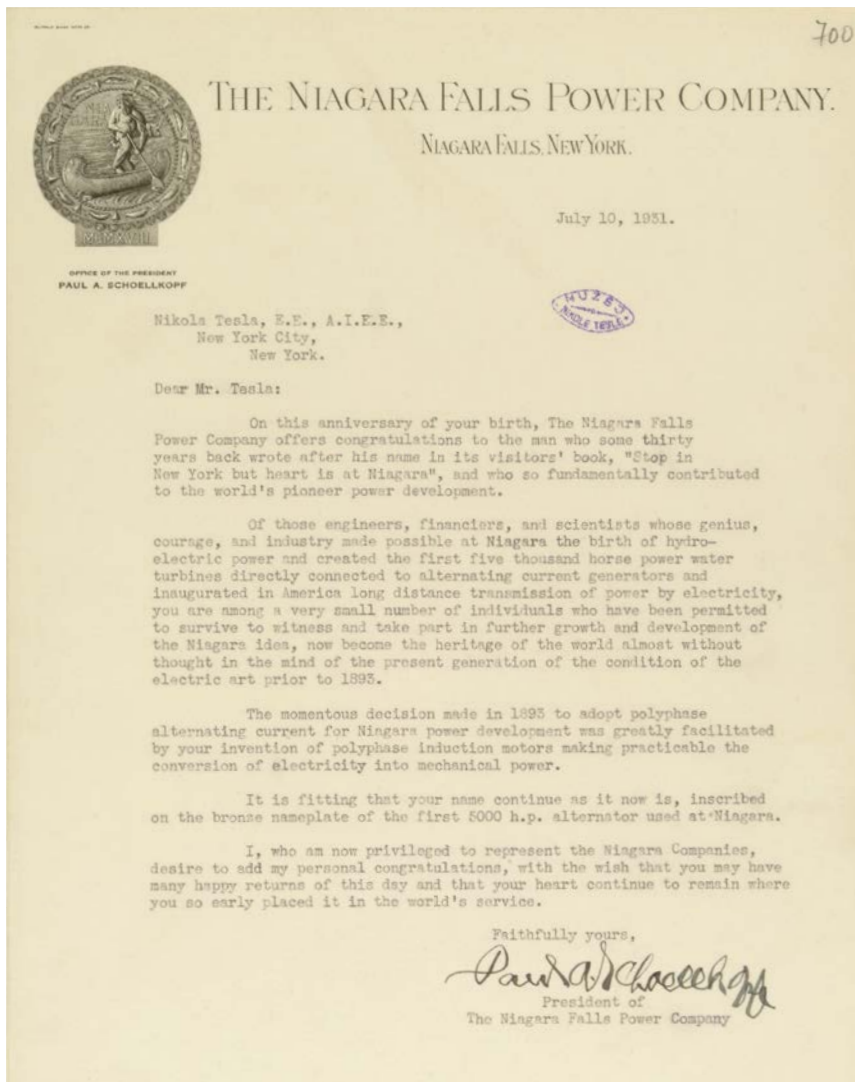

The War of the Currents of many years, which had split American industry into two camps, ended with the award of the contract to the Westinghouse Company and the recognition of the polyphase alternating current system. The victory in the War of the Currents led the Westinghouse Company to becoming a global enterprise which at the time employed 50,000 people.

Soon afterwards, alternating current was supplied to the Pittsburgh Reduction Company, which later became the Aluminium Company of America. The metal processing industry and especially the aluminium industry had waited for the necessary high voltages, which could only be supplied by alternating current, in order to be able to use fused-salt electrolysis. Aluminium was used in ship construction as well as in the manufacture of bicycle frames, zeppelins, construction facades, overhead power lines, lightning conductors and tableware. Aluminium production enabled rapid progress in the aircraft industry between the two world wars /3/.

Tesla's polyphase alternating current system prevailed due to its technical and physical advantages and is even today the most relevant public electricity supply system. The standardisation of the alternating-current frequency also served as a unified power system. Around 1900, electrical industrial companies in the USA agreed a frequency of 25 Hz for electrical transport and large motors, and 60 Hz for the normal consumer network. In Europe the public electricity network settled on a frequency of 50 Hz. Today, only the frequencies of 50 Hz and 60 Hz are encountered in public electricity networks. Special applications use diverging frequencies, e.g. 16.7 Hz in railway technology and 400 Hz in the aerospace industry.

It should be mentioned that with the development of mercury-arc rectifiers (from 1940) and powerful semiconductor components such as thyristors and IGBTs today, the economical transmission of electrical energy in the form of high-voltage direct current transmission routes of up to  $\pm 800$  kV can be implemented. With the help of the described technology, electrical energy can be exchanged between networks of differing alternating current frequencies at high efficiency. The technologies which were earlier opposed to each other in the War of the Currents supplement each other today to create a powerful and economical electricity grid.

---

High frequency,  
the Tesla transformer and  
the Wardencllyffe Tower

In addition to the development of the polyphase alternating-current system, in 1889 Tesla turned his attention to high frequency electricity and its effects. At the beginning, this was only meant to provide an improved lighting system using arc lamps. In a number of experiments, based on James Clerk Maxwell and Heinrich Hertz's work on electromagnetic waves, he developed high-frequency alternators with frequencies of up to 30,000 Hz [3]. His research culminated in the construction of a working 'resonant transformer' based on the resonance principle, which also came to be known as the Tesla transformer or Tesla coil. This device basically consisted of a spirally shaped primary and secondary winding with air at its core, a capacitor and a spark gap. In a different circuit configuration, instead of the spark gap, a high-frequency alternator is used. By means of the resonance oscillating circuit, Tesla was able to produce very high high-frequency voltages at low current strength. Tesla managed to produce voltages up to four million volts and artificial lightning five metres long in his laboratory using a Tesla coil. In later years the resonant transformer became a basis for Tesla's idea of a wireless energy transmission over long distances.

Fig.: Tesla transformer  
at the Institute of High  
Voltage Engineering and  
System Performance at  
Graz University of Technology  
(Photo/montage: Kniepeiss).

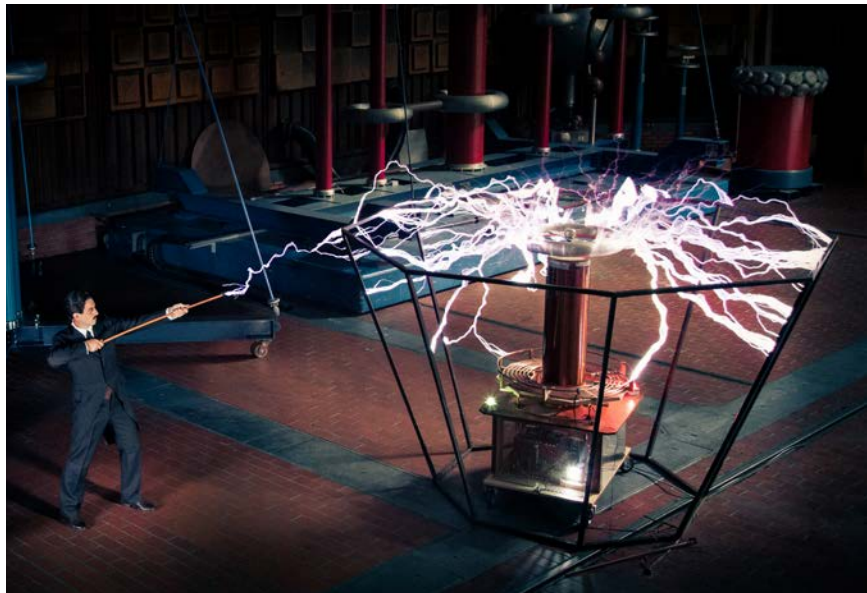

Tesla also recognised that high-frequency electricity spreads across the surface of the human body and does no damage to the internal organs (skin effect) and in 1890 he published the first results on the physiological effect of high-frequency electricity. Diathermy and Arsonvalisation, which developed out of this, has developed into an extensive field of application /3/.

Further research into the Tesla coil and electromagnetic waves led to the discovery that vacuum and Geißler tubes can be made to emit light without an electrical contact with the high-frequency coil.

Tesla presented his ideas and findings in the field of high-frequency alternating current, resonant transformers and the new wireless lamps once more to the AIEE in New York on 20 May 1891. In his lecture of several hours on 'Experiments with alternate currents of very high frequency and their application to methods of artificial illumination' at Columbia College, Tesla also demonstrated several spectacular experiments on the high-frequency phenomena he discovered in front of the specialist public.

The Columbia lecture established Tesla as a leading American inventor in the field of electrical engineering. In 1892, Tesla presented his achievements in London and Paris and thus consolidated his status as a successful inventor in Europe /2/.

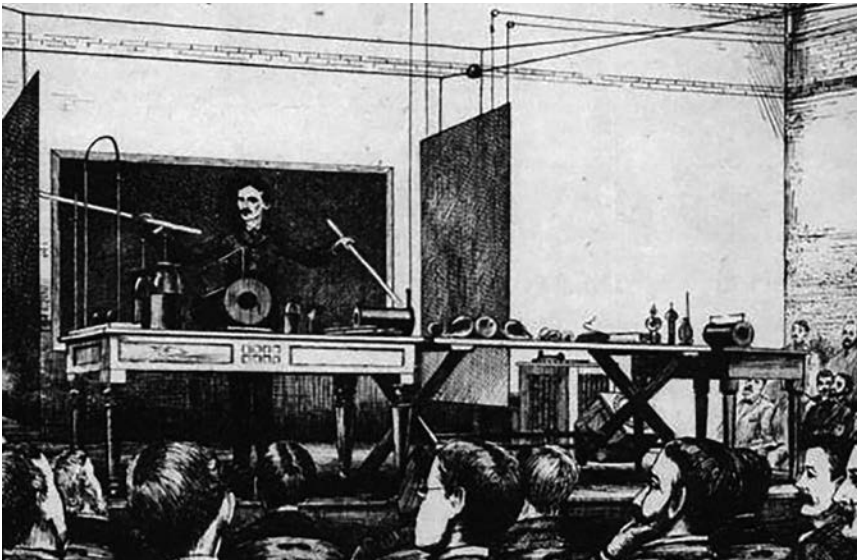

Fig.: Tesla's lecture at Columbia College in 1891 in front of the AIEE (Wikimedia Commons).



Fig.: Tesla's lecture in Paris 1892  
(Wikimedia Commons).

Tesla's experiments were fundamental for the production of fluorescent lights. They were only developed for mass production and brought onto the market five decades later. The fluorescent light has been constantly further developed and improved over 70 years and today in the form of energy-saving lamps, although its actual operating principle has not changed.

With his research into high-frequency technology, Nikola Tesla laid the foundation stone for today's communications engineering. In 1893, Tesla reported on the results of his experiments at the Franklin Institute in Philadelphia, using a variety of high-frequency oscillators which he had developed. Among other things in his lecture, he described the 'transmission of intelligible signals across some distance without the use of wires', thus detailing the basic technical principles of radio transmission. In the same year in a public demonstration in Saint Louis, Tesla managed to transmit a message from a broadcasting group to a recipient group some nine metres away. By the end of 1896, Tesla managed to carry out remote transmission from a transmitter to a receiving station some 30 km away using a long-wave frequency of 2 MHz.



Fig.: Tesla in his laboratory  
(Wikimedia Commons).

In the autumn of 1897, Tesla submitted patents for wireless message transmission and for a system of wireless energy transmission for industrial purposes. Guglielmo Marconi made use of all of Tesla's discoveries and built up a world monopoly for wireless radiotelegraphy. He is still called the founder of the radio today. Within a short period of time, radio technology spread across the whole world. After the development of undamped transmitters, radio amateurs started transmitting language and music. Broadcasting developed into a mass product as big industrial enterprises took over the production and sale of radio appliances. In the 1920s, a worldwide radio industry rapidly emerged /3/.

Tesla did not continue his work in the field of radio technology. Instead, in 1899, he became more interested in the idea of wireless energy transmission. With the help of his patent lawyer, Leonhard Curtis, Tesla was able to build a new laboratory in Colorado Springs in May 1899 which was significantly larger than his laboratory in New York.

The sides of the square-shaped lab were 30 metres long and a rod-shaped antenna extended 50 metres high from the middle of the building. In the interior of the lab was the biggest and most powerful Tesla coil that had ever been built. It had a diameter of more than 15 metres and a height of 2.7 metres, and it could produce a high-frequency voltage of almost 20 million volts. Using the world's then most powerful transmitting and receiving equipment, Tesla wanted to prove his theory that high-frequency electromagnetic waves could be used for transmitting energy. The experiments carried out in Colorado Springs confirmed Tesla's assumption that he had found a system which could transmit energy wirelessly.

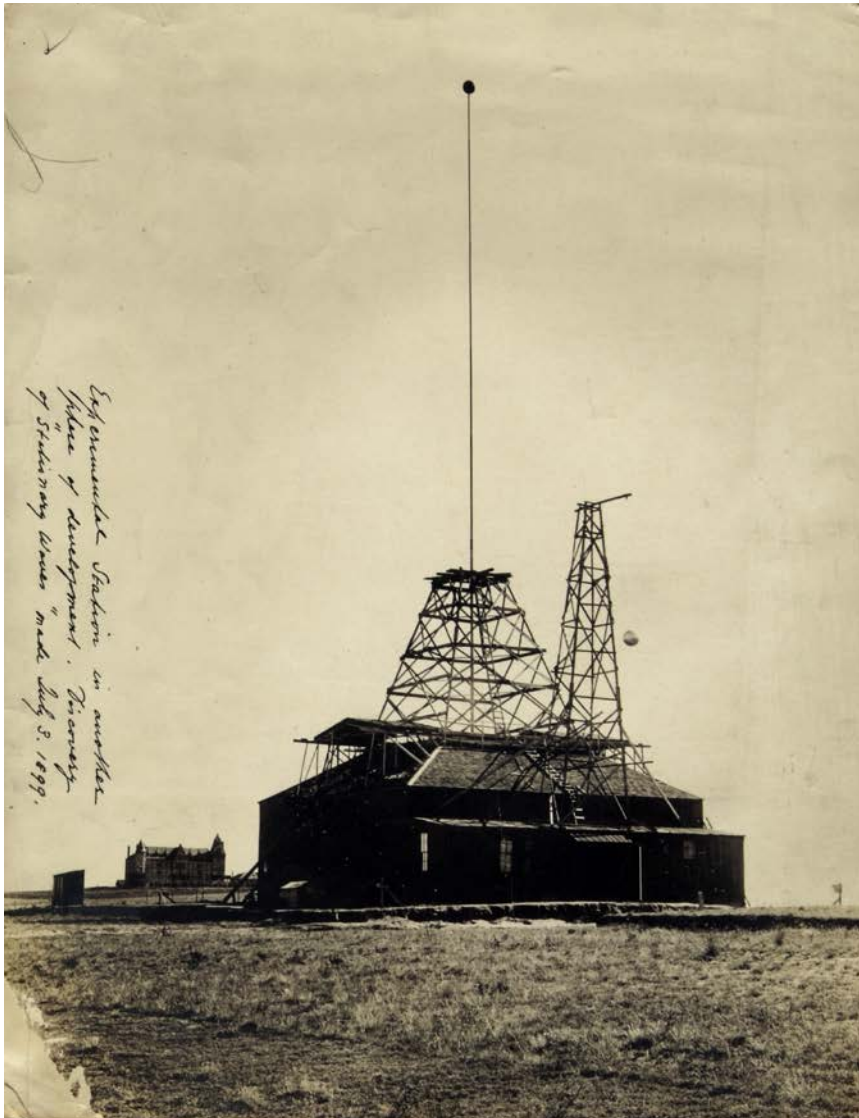

Fig.: The experimental station at Pikes Peak, Colorado, 1899 (Nikola Tesla Museum, Belgrade).

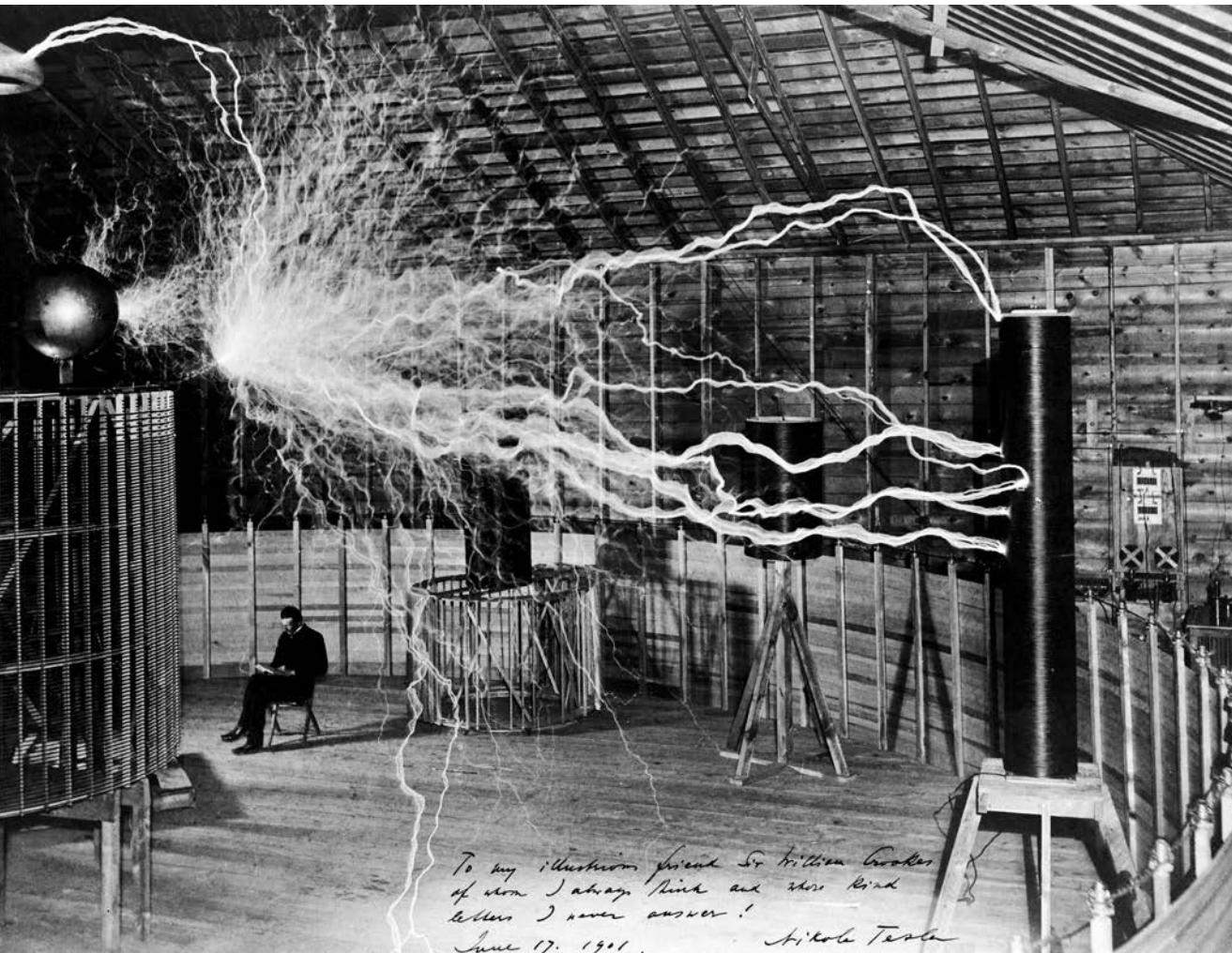

Fig.: Tesla in his laboratory at Colorado Springs (Wikimedia Commons, Welcomeimages.com, CC-BY 4.0).

In January 1900, Tesla travelled back to New York to raise capital for an even bigger transmitter and receiver to transmit energy wirelessly all over the world. He was able to win over entrepreneur and investor John Pierpont Morgan as financial backer, and managed to persuade him with pictures of his laboratory in Colorado Springs and the idea of a continuous transatlantic data transmission. Wardencllyffe Tower, which Tesla planned to build on Long Island, was about 100 metres high and 30 metres in diameter, and for structural reasons had a foundation 36 metres deep and 57 metres above ground. 100 million volts were to be produced using a Tesla coil. The construction

work on Wardenclyffe Tower proved to be time consuming and costly. Despite spectacular tests in July 1903, the project could not be completed due to a lack of funds /4/. Tesla's idea of a global wireless energy transmission remained unfulfilled.

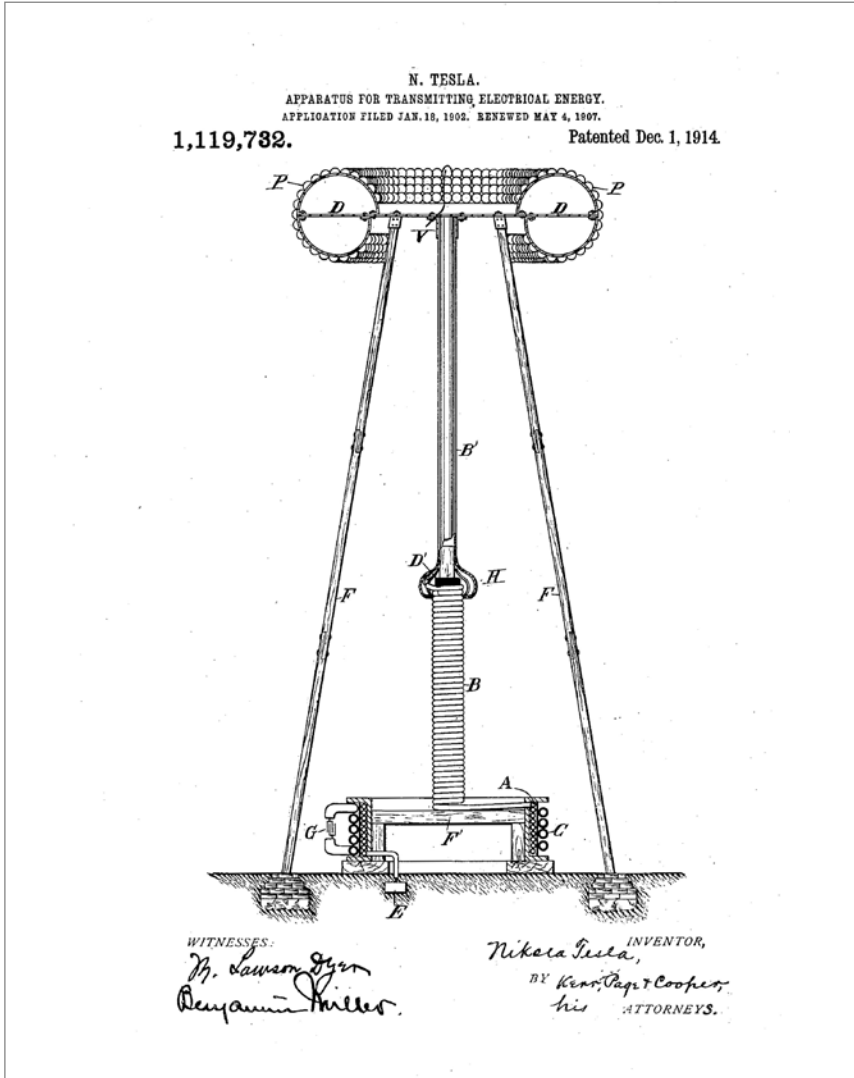

Fig.: Tesla coil as energy transmitter, US Patent 1,119,732 (Google patents).

Fig.: Laboratory and Wardencllyffe Tower (Wikimedia Commons).



---

Remote-controlled  
ships and robots

In 1898 Tesla applied for a patent for remote radio control and its use in ships and vehicles. He saw the possibility of applying the principle of wireless radio transmission in a practical way. At the first electrical engineering exhibition at Madison Square Garden in New York, Tesla publicly introduced two remote-controlled robotic ships from which his 1.1-metre-long submarine could dive.

Tesla developed remote-controlled robots for a variety of applications, and occupied himself with machines which had their own intelligence. Tesla's discoveries of wireless signal transmission were precursors of the general principles of remote control of devices, as they have been employed since the 1950s in remote-controlled satellites and drones in the aerospace industry and remote control units for televisions.

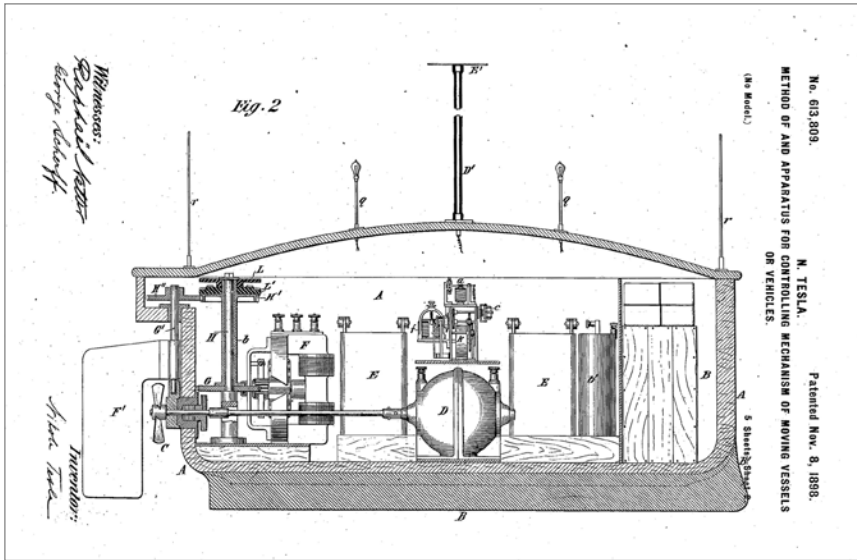

Fig.: Remote-controlled boat from 1898, US Patent 613,809 (Google patents).

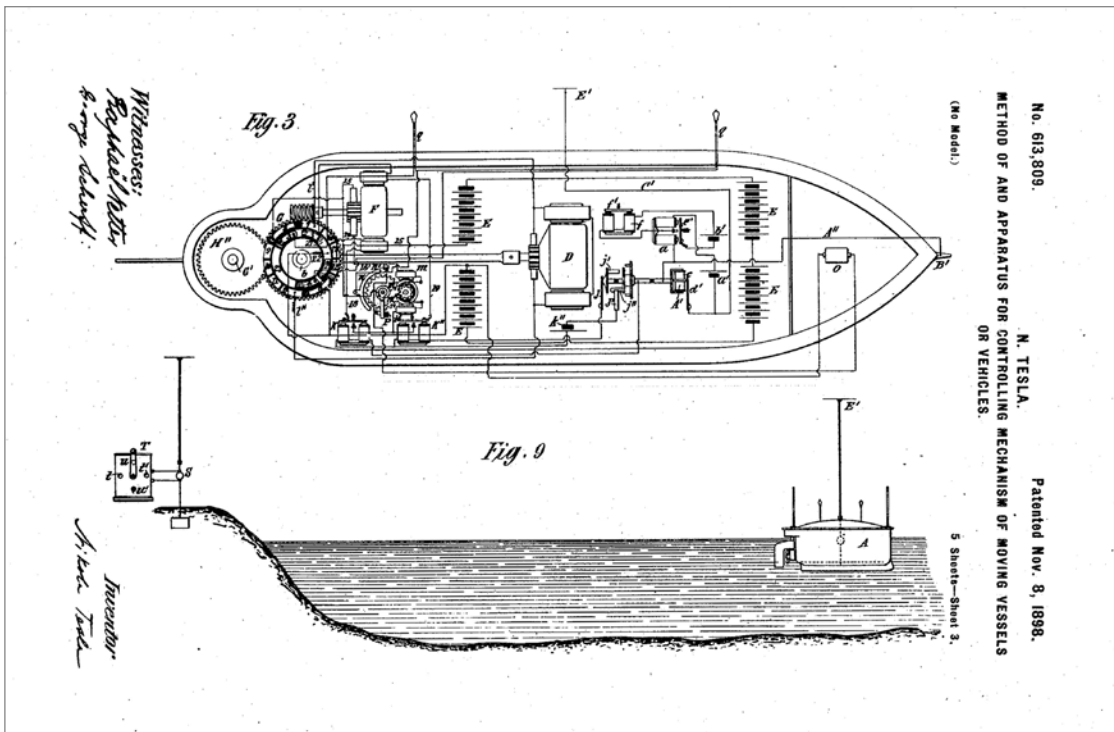

Fig.: Tesla's remote-controlled boat and transmitter, US Patent 613,809 (Google patents).

Hotel room 3327  
in New York

After the failure of Wardenclyffe Tower, Tesla had a nervous breakdown from which he only recovered in 1906. In the next years he pursued ideas of bladeless turbines as a propulsion for cars and aircraft, and developed the principle of the modern radar.

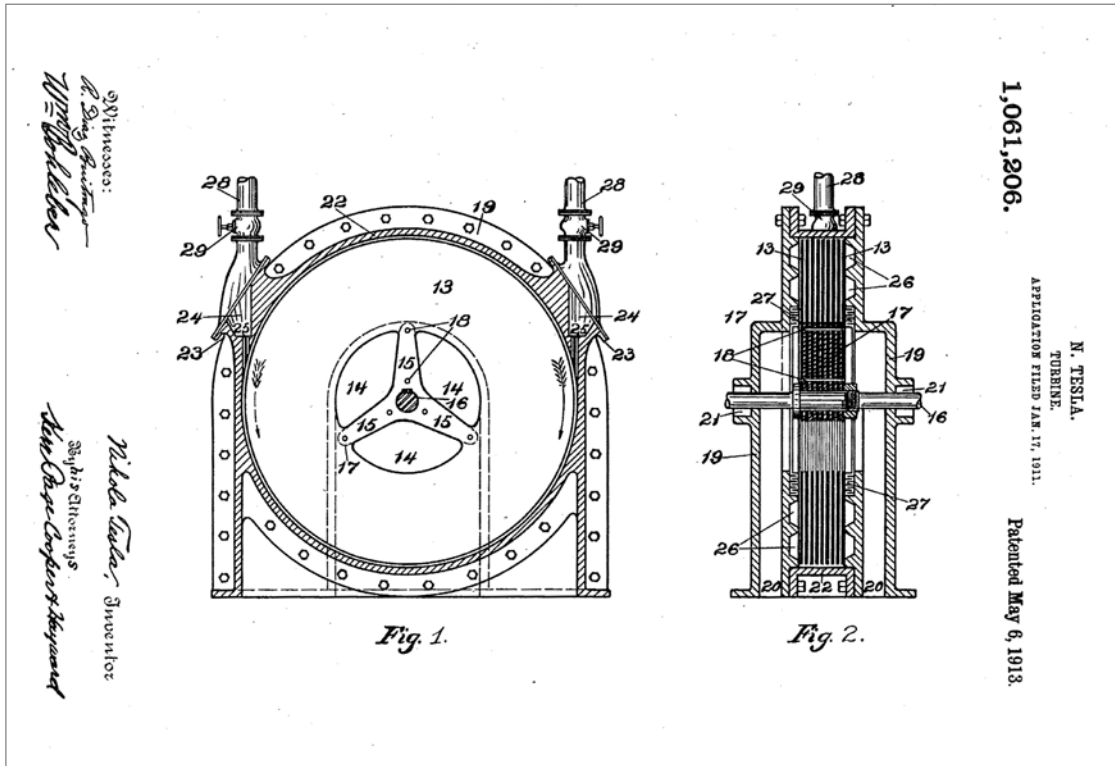

Fig.: Tesla's turbine,  
US Patent 1,061,206  
(Google patents).

All in all, Tesla could not build on his earlier successes and lived from the modest royalty fees into the 1920s. These setbacks depressed Tesla, making him withdraw more and more. His announcement of a particle beam weapon in 1934 – practical, but not to be implemented – brought Tesla back into the international limelight.

He spent the final months of his life as a recluse. On 8 January 1943, he was discovered dead in his bed in his hotel room in New York. His room number 3327 can be seen as an example of his idiosyncrasies. He loved the number 3, and the sequence of digits yield the equation  $3^3 = 3 \cdot 3 \cdot 3 = 27$ .

The Mayor of New York, Fiorello LaGuardia, honoured Tesla in his radio speech on 10 January 1943 as follows /1/:

‘He died in poverty. But he was one of the most useful and successful men who ever lived. His achievements were great and are becoming greater as time goes on.’

Tesla’s ideas and accomplishments led to two disruptive innovations which changed the American economy at the end of the 19th and at the beginning of the 20th centuries and which ultimately sustainably influenced electrical engineering in the whole world /1, 2/.

In the 1880s, his alternating current motor established the changeover from direct current to alternating current so that, in addition to lighting systems, there was also electricity available for industry and mass production. Modern versions of Tesla’s alternating current motors can be found in household appliances, industrial production halls and motor vehicles, and are also used to run hard disks in laptop computers.

His second electrical revolution was wireless energy transmission. His ideas laid the foundation for high frequency and communications engineering. Due to a lack of funds, the Wardenclyffe Tower was not able to be completed, but variations of Tesla’s ideas on coordinated electrical circuits are used in today’s radios, televisions, remote controllers and mobile phones.

---

Tesla’s innovations –  
visible in the 21st century

/1/ Michael Krause: Wie Nikola Tesla das 20. Jahrhundert erfand. WILEY-VCH Verlag, 2010

## References

/2/ W. Bernard Carlson: TESLA - Der Erfinder des elektrischen Zeitalters. FBV, 2017

/3/ Hermann Egger: Geniale Ideen und intelligente Lösungen: Teslas Beitrag zur Industrieentwicklung. Nikola Tesla und die Technik in Graz, Verlag der Technischen Universität Graz, 2006

/4/ Stefan Schlögl: Nikola Tesla - Ein Mann unter Strom. Terra Mater, September 2006

Note: The text passages in the present article on industrial development are taken from Hermann Egger /3/ and as part of an agreement have not been marked as quotations.



Constant development  
and unrelenting progress  
is the goal...

Stages in the development  
of the Universalmuseum Joanneum

by Karl Peitler, Wolfgang Muchitsch, Bernd Moser

The 'Joanneum', founded by Archduke Johann (1782 – 1859) in 1811 in the spirit of the Enlightenment and according to the new ideas of progress at the time, is the oldest and – after the Kunsthistorische Museum (Museum of Art History) in Vienna – the second biggest museum complex in Austria.

As a universal and state museum with over 4.5 million items in its collection, the Joanneum has a mission to provide a comprehensive picture of the development of the history, natural history and culture of the state of Styria through its collections in its role as a scientific and cultural institution.

The journey from an Inner Austrian 'national museum' combined with a natural sciences and technology teaching institution to the present Universal-museum Joanneum GmbH has, despite a number of changes of course, been completely successful. The institution has always been developing into a broadly based, public-oriented and modern establishment for its visitors.

But let us look back to its beginnings at the turn of the 19th century.

Archduke Johann began his statutes for the Joanneum with the general statement *'Constant development and unrelenting progress are the goal of each individual, each institute of state, and therefore of humanity' because 'standing still and remaining behind in the vibrant life of the constantly changing spectacle of the world...' are 'the same.'* This observation is particularly true for the history of the Joanneum. But one has to take into account that development goes forward in leaps and bounds; it does not have to be evolutionary, but can also accommodate revolutionary elements. Development carries in itself the propensity to change suddenly into something else.

How the Joanneum has performed its duties since it was founded can be gleaned from the annual reports of the institute in the period from 1811 to 1929, and from 1971 onwards. With this publication, the museum fulfils the mission of its founder, which is laid down in the statutes of 1811: *'At the end of each and every year, a report will be lodged about everything that has happened during this period, about augmentations, enlargements and improvements of the collections held in the museum, and about the number of visitors and the subjects they prefer to involve themselves with, what real steps of progress have been made, and about what contributions have been made and by whom. This report shall be printed after approval by the censorship authorities and announced to the province so that the vivid conviction of the institute's benefit may lead to its continuous perfection.'* The value of these records lies in their descriptive method of representation, in particular in the

listing of acquired objects year after year which, in sum, yield a genealogical description of all the collections of the Joanneum. A reflective or evaluating feature is not germane.

And then there are the commemorative publications on the occasion of the fiftieth, one hundredth, one hundred and fiftieth and bicentennial anniversaries with their articles on the development of the complete enterprise and the collections.

Notwithstanding the statement of museum expert Kenneth Hudson ‘... museums take on the colouring of the society in which their activity takes place...’, underlying tendencies should be unravelled after the fact and light cast on the marks that have been left on the present form in the course of the development of the museum.



Fig.: Deed of donation from 16 July 1811, (original in the Styrian Provincial Archives).

---

Foundational motivation  
and its classification in  
the history of museums

The statutes of 1 December 1811 reveal how the founder, Archduke Johann, saw the tasks and goals of his institution: *'The necessity to set well-founded knowledge in the place of superficial pseudo-knowledge, to turn one's attention unremittingly to the highest national matter, to education, has never recommended itself so dearly as in our times. To participate in this great purpose and to at least bring it closer in a great province of the imperial state, in Inner Austria, is the aim of the national museum. The same shall be understood in all objects belonging to the circle of national literature. Everything that nature, the change of time, human diligence and perseverance have produced in Inner Austria, what the teachers of the various public institutions present to their inquisitive pupils. It is intended to sensualize them, thereby facilitating learning, to stimulate the appetite for knowledge, that of independent thinking, and thus to help with the independence of such a detrimental mere memorization, to fill more and more that harmful gap between the concept and the view, the theory and the practice.'*

With these remarks in which the educational intentions of the museum are expressly emphasised, it is generally held that Archduke Johann is caught up in the world of ideas of the late Enlightenment, and that the goal of his donation consists in serving it. Supplemented by and from the view point of historical museology, it can be added that Johann also represented an approach which can be traced back in terms of the history of ideas to Gottfried Wilhelm Leibniz, Claudius Clemens and Johann Valentin Andreä up to Samuel Quiccheberg, the founder of modern museum theory.

The philosopher Leibniz (17th c.) saw in chambers of art and rare items only collections of didactic aids. In his view, the role of a museum was primarily to communicate a better knowledge of its objects. The French Jesuit Claudius Clemens declared in his programme of an ideal museum published in 1635 *'The structure of a museum or a library, whether for private or public use,'* that real objects are necessary in order to understand written content: *'To a complete library belong not only good books of all types, but also certain instruments and devices without which the books can hardly be fully understood nor certain knowledge acquired.'* In 1618 Johann Valentin Andreä pointed out in the draft of his Utopia, Christianopolis, that acquired knowledge from books only leads to education when it is supplemented by an engagement with authentic objects which are exhibited in collections.

Samuel Quiccheberg, lastly, expressly emphasises the pedagogical intention he pursues in his museum. This can be recognised in the programmatic title of his publication which appeared in Munich in 1565:

*'Captions or guiding principles of an all encompassing exhibition building that comprises individual objects and marvellous pictures in the totality of things in such a way that they could be designated correctly. A repository of artistic and wonderful things, all rare treasures and valuable devices, figurative and pictorial representations which are here in this exhibition building collectively brought together, so that through their frequent consideration and touch a unique knowledge of things and an admirable understanding can be acquired quickly, easily and without effort.'* Quiccheberg thus sees his *'theatrum amplissimum'* not as a place of amusement and entertainment, but rather of utility, which manifests in the acquisition of knowledge (*cognitio*) and understanding (*prudencia*).

Ultimately, Archduke Johann, Leibniz, Claudius Clemens, Valentin Andreä and Samuel Quiccheberg stand in a tradition with this view, which goes back to Aristotle (384 – 322 B.C.), who was most certainly the first philosopher who carried out research and teaching on the basis of special collections of authentic objects. The above-mentioned persons represent an extroverted and open type of world view which has its gaze firmly directed at the outer world.

It is also typical of the Archduke that his foundation serve solely practical use and not aesthetic enjoyment. He enunciates this clearly in a letter to the governing board in 1825: *'The purpose of the Institute... is to be useful to the province. It was the intention to teach exactly those branches which up to now had been missing in the educational establishments of the province and which could make an impact on important branches of culture and industry.'*

Fig.: The Lesliehof around 1700, oil painting with a view to the east and with the coat of arms of the Leslie family in the hands of a putto, artist unknown. (Collection of Alte Galerie, UMJ; photo: UMJ, N. Lackner).



---

**Original scope**

The scope of the museum laid down in the founding statute of 1811 comprised eight fields:

- 1) History; various materials are enumerated in seven subgroups;
- 2) Statistics;
- 3) Physics and mathematics;
- 4) Natural history;
- 5) Chemistry laboratory;
- 6) Practical agriculture;
- 7) Technology;
- 8) Library.

The prominent position of history can probably be explained by the enthusiasm that Johann had felt for this subject since his earliest youth and also by the belief that the knowledge of the history of a people was the path to self-knowledge – a conviction which the Archduke had most probably taken on from his teacher, the Swiss historian Johannes von Müller.

The Archduke formulated the fundamental importance of the subject of history in his letter of 16 September 1811 to all the districts of the Duchy of Styria and Carinthia requesting them to send historical monuments to the new institute: *"It is shameful to be a foreigner in one's own country" was the saying of one of the wisest statesmen of antiquity, and was the firm, intimate conviction of all excellent men and patriots, past and present. A knowledge of the physical and natural history of the country is indispensable, but a no less comprehensive and highly important repository of the wonderful teachings of experience is granted by history.'*

It is characteristic of the Archduke's enlightened view of the world that he calls Marcus Tullius Cicero (106 – 43 B.C.), the most important representative of the free state at the time of the late Roman Republic, as a witness to the importance of knowledge of one's own history. In his dialogue *'De Oratore'* (written around 55 B.C.), the latter asks a main sub-speaker of the conversation about the ideal speaker the following question: *'Why can't we therefore also be sufficiently equipped in civil law – especially since the processes, the business and the forum take up a lot of our time – at least for not acting like strangers and newly arrived persons in our own homeland?'* Archduke Johann places the bon mot of the stranger in his own homeland, associated by Cicero with the knowledge of the civil law and the laws of the old time, in the new context of having knowledge of one's own history.

The practically minded Archduke Johann speaks of the other subjects listed in the statutes and, against the background of the incipient industrial revolution, anchored precisely those disciplines at his institute which were necessary for coping with this time, but until then had not been considered in the educational canon of the Inner Austrian educational institutions.

After its foundation, the institute showed a clear and uniform line of development as an educational institution with technical and scientific subjects. The path led from the expansion of this educational institution (1827 – 1847) via the regional polytechnic and the technical college (1848 – 1866) to the state technical college (1874) and to the final and spatial separation of the museum area and the technical college by its inner-city relocation to Rechbauerstraße (1888).

---

Outline of the course  
of development

But not only did the professorial chairs start to become independent, at the same time the long-standing efforts to reorganise the Joanneum as a museum gained success. In the late eighties of the 19th century an end point of the development was reached, and the new finally found its expression in the programme of the organic statute of 21 January 1887.

Accordingly, the following two sections in the history of the Joanneum can be distinguished: the early Joanneum from 1811 to 1887 and the Joanneum of the later period from the organic statute of 1887 until today.



Fig.: The parent house of the Joanneum (Lesliehof), northern courtyard with the monument of the founder of the Mohs scale of hardness, Friederich Mohs.  
(Photo: UMJ, N. Lackner).

With the Joanneum, Archduke Johann primarily wanted to create an educational institution that would illustrate its teaching through the use of authentic objects. An overview of the following years shows that the institute, driven by the will of the founder, consistently followed this path despite some difficulties. Already in the year 1812, free and public lectures on scientific fields of knowledge were held. Mineralogy was taught by the famous scholar Friedrich Mohs, employed at the Archduke's private expense, botany and chemistry by Lorenz Chrysanth von Vest, experimental physics and astronomy by Johann Philipp Neumann, professor at the Lyceum, and technology by Franz Jeschowsky, professor of mathematics at the Lyceum. It should not go unmentioned in this context that the appointment of the scholars did not take place by means of the prescribed public tendering procedure, but rather they were selected from the most capable available men, with 'expert hand'. From 1818, a lecture on zoology was added, and as a result of the foundation of the Imperial and Royal Agricultural Society in 1819, the (professorial) chair of agriculture was transferred from the Lyceum to the Joanneum in 1825. The year 1827 was a milestone in the development of the Joanneum as an educational institution. In this year the study department was organised and a director of studies was appointed in the person of the curator Ludwig Crophius, abbot of the Cistercian monastery Rein. In the same year, a chair of technical-practical mathematics was established. The Joanneum had thus become a polytechnic, an educational institution that otherwise existed in the monarchy only in Vienna and Prague. 1829 saw the establishment of two independent chemistry and physics chairs, and a metallurgy chair was applied for in the same year and approved by the Emperor. However, lessons could not begin until December 1840 in a building specially erected for this purpose in Vordernberg. In 1838 the decision was taken by the estates to establish a secondary school, in which background knowledge for studying at the Joanneum was to be imparted. Subsequently, the Joanneum set up chairs for mechanics, mechanical engineering and technical drawing, higher mathematics as well as practical and descriptive geometry. In 1845 the professors at the Joanneum were put on an equal footing with their Viennese and Prague colleagues.

Fig.: Cultural property plaque next to the entrance gate to the Joanneum, Raubergasse 10, Graz. (Photo: UMJ, N. Lackner).



A detailed overview of the development of the collections in the first fifty years of their existence is provided by the vice-director of studies and curator Georg Göth in the 50th anniversary commemorative publication. For 1861, this describes the scope and organisational structure of the collections as follows:

- 1) Natural history collections (botanical collection with the botanical garden, zoological collection, mineralogical collection with the geognostic and palaeontological collections)
- 2) Historical and archaeological collections (collection of documents, collection of coins, antique cabinet)
- 3) Commercial product collection
- 4) Agricultural collection
- 5) Library

The period after Archduke Johann's death in 1859 was marked by the conflict between the board of trustees and the professorial council, which wanted to be directly subordinated to the provincial committee (the executive body of the provincial parliament or Landtag re-established in 1861). This was done with the adoption of the organic statute of 25 April 1864. This meant that the Joanneum was elevated to the rank of a college of technology or a technical university. As a consistent continuation of this development, the Landtag (provincial parliament) issued a statute regarding the Joanneum collections and the library on 17 December 1866, by which the board of trustees was abolished, the collections and their directors placed under the direct care of the provincial committee, which appointed a separate official in charge of the Joanneum. The statute of 1866 distinguished the following areas:

1) Historical collections (archive, coin and antique cabinet); 2) Natural science collections (mineralogical, geognostic and palaeontological cabinet, zoological cabinet, botanical cabinet with botanical garden); 3) State Library.

Over the next few years, the College of Technology was separated from the collections in terms of organisation and space. In 1874 the educational institution was taken over by the state, but it was not until 1888 that it was able to move into the newly built building in Rechbauerstraße. In 1868, the Joanneum Archive, which had been collected since 1811 and comprised a wide range of archives of Styrian provenance, was merged with the Estates Archive to form the Styrian Provincial Archives and moved to the vacated premises of the secondary school in Hamerlinggasse. Thus the archival collection area was also separated organisationally from the Joanneum.

Fig.: Floor plan of the first floor of the Joanneum ca. 1860 with lecture hall and room names. Some of Nikola Tesla's classes were held in room No. 7 (Lecture Hall V for technology). Original: Styrian Provincial Archives, by the kind mediation of Mag. Dr. B. Reismann, Archive of TU Graz).

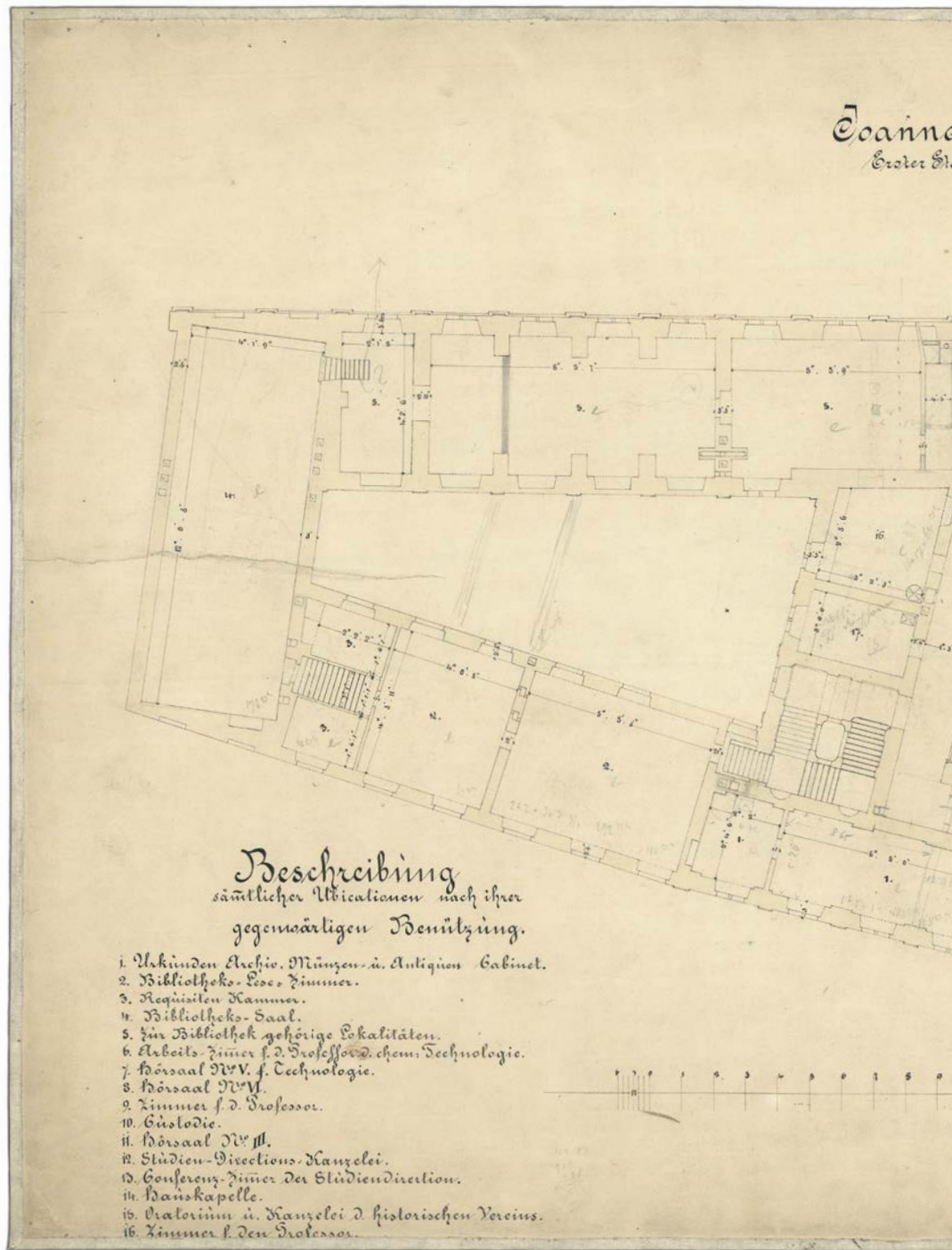

rium  
ockl.



4 x 19 1/2 x 10 1/2  
2 x 24 1/2 x 12 1/2  
1 x 24 1/2 x 7 1/2

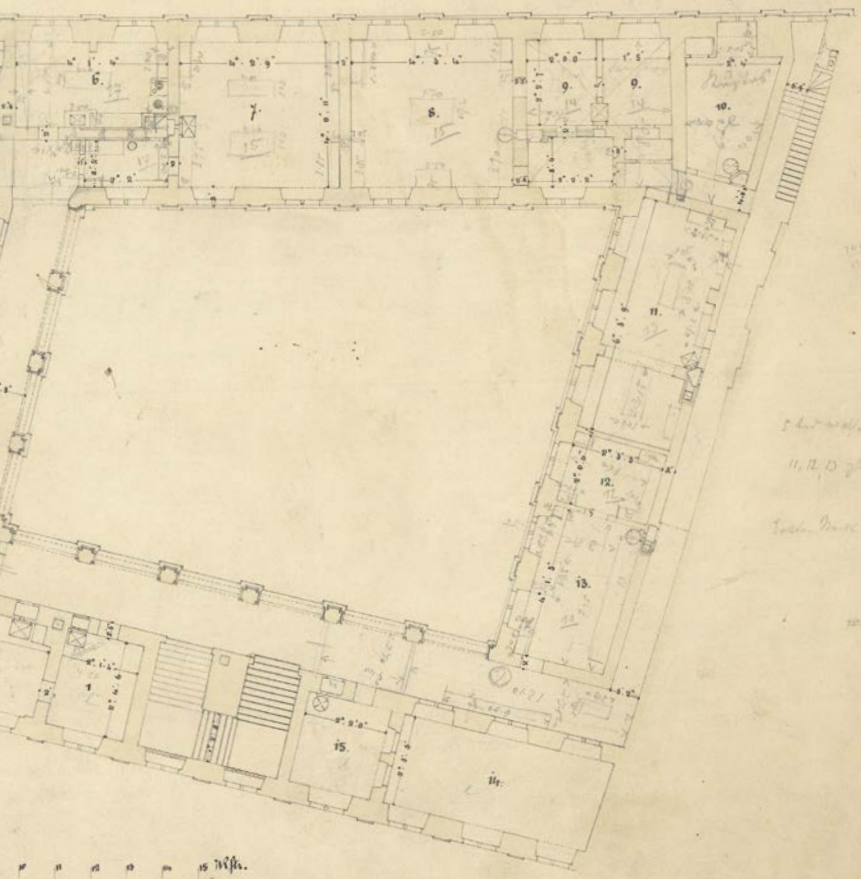

1st floor, 11, 12, 13, 14, 15  
11, 12, 13, 14, 15  
11, 12, 13, 14, 15

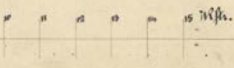

M44a/12

This separation meant that only the library and the museum collections were left to the Joanneum. It was now obvious that it had to be transformed into a state museum and expanded. The immediate cause was a motion by the member of the provincial parliament, Gundakar Graf Wurmbrand, in the Landtag on 17 October 1878 to set up a commission of inquiry *'to maintain surveys and work out proposals on how a reorganisation of the Joanneum and the formation of a state museum could be carried out'*. The activities of the commission, which included Franz Graf Meran, Gundakar Graf Wurmbrand, Dr. Moritz von Schreiner (the Joanneum official in the provincial committee) and Prof. Dr. Johann Rumpf (as representative of the heads of the collection), covered the period from 1878 to 1884.

The mere fact that this commission was not set up until 1878 – twelve years after the statute was enacted and four years after the College of Technology was taken over by the state – and that its work dragged on for six years, shows how much effort it took to persuade the Landtag to make a definitive decision on the continued existence of the Joanneum. Although it is not explicitly emphasized in the sources available as printed works, one cannot avoid the impression that there will also have been a position in the Landtag, based on financial considerations, to separate the Joanneum collections from the care of the province or to use them as capital in the negotiations with the Imperial and Royal Ministry of Education on the financing of the new site of the Technical University. However, in accordance with the proposals of the commission of enquiry, the Landtag decided on 5 July 1880 to *'provisionally preserve all currently existing collections in their entirety. In the interest of the future character of the Joanneum as a state museum, however, it was desirable that from now on objects relating only to Styria and those of Styrian origin should be acquired by purchase'*. Nevertheless, the sale of the botanical garden and the surrender of a large number of collection objects to the College of Technology imposed sensitive sacrifices on the Joanneum.

The Joannean cause received unexpected support in 1883 with the large anniversary exhibition on the occasion of the 600th anniversary of Styria's affiliation to the house of Habsburg, which awakened public awareness and provided the commission of enquiry with supportive argumentation for the pursuit of its goal. In the same year, the Landesmuseumsverein Joanneum (Association of the State Museum Joanneum) was founded, whose remit was to enrich the existing state collections and shape them in a contemporary way. Members of this association included, among others, Franz Graf Meran, Gundakar Graf Wurmbrand and Karl Lacher.

After long negotiations between the association and the commission of enquiry on the one hand and the Provincial Committee on the other, a new organic statute was adopted by the Landtag on 21 January 1887, with which the collections united in the Joanneum were to be transformed into a state museum.

As a state institution, it was directly subordinated to state representation and the Provincial Committee. The board of trustees, which was abolished in 1866 and now reinstated, was added to it as a permanent advisory board in all Joanneum matters. The latter also had to supervise the activities of the civil servants and custodians and be granted insight into their scholarly activities.

The number of collections to be included in the State Museum Joanneum was increased to eleven:

- 1) Geological-palaeontological collection;
- 2) Mineralogical collection;
- 3) Botanical collection;
- 4) Zoological collection;
- 5) Prehistorical collection;
- 6) Coin and antique collection;
- 7) Collection of works from the Middle Ages, the Renaissance and modern times (cultural-historical collection in the narrower sense);
- 8) Armoury;
- 9) Picture gallery and gallery of prints;
- 10) State library;
- 11) Styrian Provincial Archives (in external association with the Joanneum).  
The collections were already grouped into a natural sciences, art and history department.

The importance of the organic statute lay in the fact that the management of the Joanneum was reorganised and its programmatic scope redefined. In addition it gained a new version of its purpose and self-conception oriented towards universality, which, pre-formulated in the founding statutes of 1811, now received its classical and still valid form: *'The Styrian State Museum should reflect a comprehensive picture of the historical and cultural development of the state and its inhabitants and contain as complete a presentation as possible of its natural products. The knowledge of the homeland shall be promoted in all fields of scientific research, and the sense of artistic creation awakened'*.

---

The Joanneum from  
1888 to 2002

In the following years, as part of the implementation of the organic statute, the partially outsourced collections were returned to the Lesliehof in Raubergasse 10, which had now become vacant, and reorganised. However, a new building was unavoidably necessary to house the newly created cultural-historical collection and the picture gallery of the drawing academy of the estates, which had been combined with the collection of important Styrian works of art dating back to Archduke Johann. This was built at Neutorgasse 45 between 1890 and 1895 according to plans by August Gunolt. At the same time, an extension to the Lesliehof was erected for the state library. Hand in hand with this was the neo-Baroque design of the façade of the wing of the Lesliehof in Raubergasse, which was extended to the south in 1825 and 1826. With the move to the library building at Kalchberggasse 2 in 1893, the state library was practically separated from the Joanneum.

These structural measures stood at the end of protracted discussions about the expansion of the Joanneum and were also supported by the consideration that – should a further expansion be necessary in the future – this could be done by the inclusion of a building in Kalchberggasse, which would connect the museum in Neutorgasse with the state library and thus create a uniformly used overall facility. But also the north wing of the museum building at Neutorgasse 45 was designed in such a way that the possibility of a connection with the museum building at Raubergasse 10 was left open. This original and obvious idea of linking the two houses was considered before the Second World War in view of the need to adequately accommodate the growing holdings of the state art gallery, and was also re-introduced in the years before 2002 into the considerations about restructuring the Joanneum.

The takeover of further collections and buildings into the care of the Joanneum undoubtedly represents one of the main trends in the development up to the present day. In the course of time it became the largest Austrian provincial museum. Whereas in 1911 – the year of the 100th anniversary of the Institute – there were just three buildings, later on the following nine buildings with historically valuable structures were entrusted to the State Museum for use as collection sites and for the most part also for preservation: Museum building at Raubergasse 10 (since 1811), the State Armoury (since 1892), museum building at Neutorgasse 45 (since 1895), museum building at Paulustorgasse 11-13a (since 1913), Palais Herberstein (since 1941) as a long-term location for the art collections of the 19th and 20th centuries after the state art gallery was divided into an Alte Galerie and a Neue Galerie, Eggenberg Castle

(since 1947), Trautenfels Castle (since 1952), parts of Stainz Castle (since 1966) and Palais Attems (from 1997 to 2006), which housed the photographic and sound archive established in 1960. Only one of these buildings was built for its use as a museum – the one at Neutorgasse 45.

On the other hand, with the Kunsthaus in 2003, as Graz was the European capital of culture, a building was added that has already been attracting worldwide attention.

In 1913, on the basis of a special folklore exhibition shown in the museum building at Neutorgasse 45, the provincial committee decided on a plan to establish a museum for folklore. The initiative for this came from Viktor von Geramb, the then secretary of the board of trustees, who was also commissioned to set up and design this collection.

Already in his contribution to the commemorative publication on the centenary of the Joanneum, von Geramb explained the importance of Archduke Johann for Styrian folklore. He found the justification for the creation of this new collection at the Joanneum in the founding statutes of the institute, in which the Archduke had also named the field of 'statistics' among the subjects the institute was to illustrate. According to Johann, statistics as a descriptive science also had to include 'the traditional costumes, folk festivals and domestic life' of Inner Austria. Thus Geramb was able to derive from the statutes of the Joanneum the justification for his extension by a subject which had not been developed as an independent discipline at the time the Joanneum was founded. The establishment of the Folk Life Museum at the Joanneum had the immediate consequence that folklore could establish itself as a scientific discipline and that a chair for folklore studies (Ethnology) was established at the University of Graz as a university novelty.

Geramb's initiative ultimately led to the later expansion of the folklore department at the Joanneum through the takeover of the Landscape Museum in Trautenfels Castle in 1952 and the establishment of a permanent branch of the Folk Life Museum in Stainz Castle following the 1966 provincial exhibition 'The Styrian Farmer'. The founding of a museum for biotechnology and hunting at the Joanneum in 1941 and its realisation in 1949 can also be seen from this perspective. The term biotechnology was soon no longer in use, but today it seems very modern again.

Discussions on the legal form of the Joanneum had already taken place when the statute of 17 December 1866 was adopted. In the interwar period, however, this question became a pressing one in so far as the financial plight of the country gave rise to considerations to sell objects of the Joanneum collection or to use their value as cover for credit operations. In this context, curator Dr. Max von Archer wrote a memorandum in which the legal character of the Joanneum was proven to be a foundation and thus the inviolability and inalienability of its holdings was demonstrated.

An important organisational change took place in 1936, when the secretary of the board of trustees, who according to the organic statute of 1887 had to manage the administrative business of the departments on behalf of the board of trustees, was appointed not only director of the institute by the state government, but also at the same time as head of the newly established department of art and science. In addition, in 1938 the board of trustees was not reconvened after the end of its term of office.

After the war, the old state before 1936 was restored, when the state government transferred the management of the organisation to a newly constituted board of trustees. However, the fact that the state government had close ties to the top management and administration of the museum directly subordinated to it is shown by the fact that until 1957 the active cultural official of the state government was also on the board of trustees of the Joanneum.

From 1962, the secretary of the board of trustees was again appointed head of legal department 6, which was responsible for art and culture. The latter now exercised the competences he was entitled to as secretary of the board of trustees. These included above all the preparation of the budget for the Joanneum and the personnel management of the organisation – only in his position as head of legal department 6. After his retirement, these powers were not passed on to the new secretary of the board of trustees or to the director reinstated in 1970, but remained within the remit of legal department 6.

As a result, the State Museum Joanneum lost its direct link to the state government, which had always existed, and instead became a subordinate department for the next 33 years.

Seen diachronically, the Joanneum had come to a dead end in its organisational development, similar to the 1860s. The dynamics emanating from the organic statute of 1887 had ebbed away in a similar way to the momentum of the founding years. New paths had to be taken.

At the end of the 1980s, the first concrete steps were taken to remedy this unsatisfactory situation. After many years of discussion, the Joanneum staff developed a new organisational structure for the whole museum, regulating internal organisational relationships and processes, and a presentation form for its collections that meets modern requirements. The concept for the permanent exhibitions and the space concept were finally completed in 1997, and the first important steps could be taken in their realisation. At the beginning of the 1990s, a search for a new legal form for the Joanneum was undertaken. A Joanneum committee was set up by the state government to draw up a proposal for the establishment of a private company form, namely a limited liability company. In 1993, this committee presented a final concept including the necessary draft treaties and a proposal for the necessary amendment of the state constitution. Since, however, the State of Styria had only just carried out the spin-off of the provincial hospitals into a limited liability company and this project had not proceeded as seamlessly as expected, especially in personnel matters, the reform of the Joanneum was not further implemented. The discussion process of the early nineties finally led to the result that in 1995 the State Museum Joanneum was elevated to a separate department of the office of the Styrian state government with direct subordination to the state government and the ability to make at least partially autonomous decisions. The director of the Joanneum was thus also the head of the State Museum Joanneum department.

A new initiative was taken by the Styrian parliament with its resolution of 28 September 1999, which called on the state government to ‘...develop an organisational model for the State Museum Joanneum in order to allow its management level greater autonomy, greater flexibility in budget management and multi-year planning for the fulfilment of tasks...’ A resolution was passed by the state government on 11 October 1999, and in October 2000, on behalf of the state government, a steering team together with the board of trustees and the staff representatives drew up a jointly supported concept for the future legal and organisational form of the Joanneum. It recommended the establishment of a public-law institution on the basis of a statutory regulation.

Shortly afterwards, however, there was a change in the responsible minister for culture, who arranged for a new review of the legal form of the Joanneum. Finally the establishment of a non-profit limited liability company was given preference. In this spirit, the state government of Styria passed a unanimous resolution at its meeting on 2 July 2001 to transfer the administration of the State Museum Joanneum from the state government to a non-profit limited liability company.

Fig.: The Kunsthaus Graz,  
evening view from  
the Schlossberg.  
(Photo: UMJ, N. Lackner).



As of 1 January 2003, the State Museum Joanneum was spun off from the state administration into a limited liability company. At the top of this limited liability company, two managing directors under commercial law were appointed: an artistic director and a scientific director initially, but from 2018 a scientific and a financial director whose division of tasks is laid down in the company's own rules of procedure.

The interests of the owners, the State of Styria (85%) and – due to the management of the Kunsthaus Graz – the City of Graz (15%), are safeguarded by the general assembly and a supervisory board consisting of nine capital representatives (seven representatives of the State of Styria, two representatives of the City) and five employee representatives.

Compared to before, the limited liability form (GmbH) provides the management with a very large degree of autonomy in its decisions, more room for manoeuvre regarding budgeting and thus with the planning of longer-term projects, a larger transparency in the cost and performance calculation and a higher measure of flexibility regarding personnel. In addition, the acquisition of additional financial resources (sponsoring, etc.) is also much easier.

The Universalmuseum Joanneum employs over 500 permanent staff, including supervisors and educators, to fulfil the diverse tasks of a museum, namely collecting, researching, documenting, conserving, exhibiting and communicating.

In recent years, around 600,000 visitors a year have seen up to 70 temporary exhibitions a year. Countless lecture events, discussions, excursions, family and children's tours are always an important addition to the presentation of objects in the permanent collections and temporary exhibitions.

The official cooperation sector with other large educational institutions such as the University of Graz and Erzherzog Johann University (TU Graz) has also recently been given strong impetus – namely with regard to opening up new groups of interested parties.

The presentation of the numerous collections is currently taking place at fourteen locations, which – with the exception of the Kunsthaus Graz (2003), the pavilion building Flavia Solva (2004) and the Archaeology Museum (2009) – are historic buildings: the castles of Eggenberg, Stainz and Trautenfels, the Landeszeughaus (Armoury), the Volkskundemuseum (Folk Life Museum) housed in a former monastery complex, the Lesliehof in Raubergasse which was built as a town house of the Benedictine monastery of St. Lambrecht, (the parent building of the Joanneum) as well as Palais Herberstein in Sack-

strasse and the building erected between 1890 and 1894 in Neutorgasse – all buildings with the corresponding problems of preservation and monument protection during the adaptations for modern exhibition presentations.

In preparation for the 200-year anniversary in 2011, the State of Styria made considerable investments since the end of the 1990s in order to renovate some of the museum locations and to present the permanent collections anew. These included, among other things, renovations in the area of the collection presentations in Trautenfels and in the Folk Life Museum, the relocation of the Alte Galerie to Schloss Eggenberg and the Jagdmuseum (Hunting Museum) to Schloss Stainz as well as negotiations and plans for the redesign of a museum complex in the Neutorgasse/ Raubergasse/ State Library area from 2003.

In 2007 the running of the Austrian Sculpture Park private foundation in Unterpremstätten south of Graz was taken over by the Joanneum. In 2009 the 'State Museum' Joanneum was renamed 'Universalmuseum' Joanneum to give a new and more accurate expression to the diversity of the collections.

To mark the 200th anniversary of the Joanneum in 2011, the Neue Galerie, the multimedia collections and the visitor centre were opened in the newly renamed Joanneumsviertel (Joanneum district). After the Neue Galerie and the cultural history collection were relocated, the latter was opened in spring 2011 under the name Museum im Palais at the Palais Herberstein in Sackstrasse. In the same year, the Institute for Art in Public Spaces, associated since 2006, was merged with the Sculpture Park in the Art in Outside Spaces department. The Natural History Museum opened in spring 2013 in the Joanneumsviertel, marking the culmination of the major project 'Joanneum Neu'. In order to have enough space for the new Natural History Museum, the scientific collections of the four natural history collections including the staff and all offices, laboratories and workshops had already been housed in the specially adapted study and collection centre in Weinzöttlstrasse in Graz-Andritz in 2010. The Styrian State Library is another user of the areas in the new Joanneum district – no longer part of the Joanneum, but closely linked to it historically.



But the enlargement was not yet complete. In 2014, the state memorials, the Rosegger museum at Krieglach and the Rosegger birthplace on the Alpl were transferred from the cultural department to the administration of the Universalmuseum Joanneum. In 2017 the Palais Herberstein/Sackstrasse 16 was repositioned as the History Museum in which the cultural-historical collection is represented with a show depot. A separate exhibition area is dedicated to the multimedia collections, and temporary exhibitions on regional historical themes are shown.

Since 2019, the Austrian Open Air Museum in Stübing, north of Graz, has been the latest addition to the Universalmuseum Joanneum. And in the Natural History Museum, the CoSA (Center of Science Activities) will also be set up in 2019 in cooperation with the Graz Children's Museum 'Frida & Fred', in order to provide young people aged ten and over with a playful approach to natural science and technology, thus bringing them back very close to the original founding idea of Archduke Johann.

Fig.: Since 2011, the Joanneum's main building (now the Natural History Museum and CoSA) and the Styrian State Library (both on the left) have been connected underground to the 'new' Joanneum building from 1895 (now the Neue Galerie, on the right) via a visitor centre in the first basement floor of the newly designed Joanneum district. (Photo: UMJ, N. Lackner).

Thus it can be seen that the two terms that characterise the beginning of the Joanneum organisation as a vision under the rule of ideas of Archduke Johann can without hesitation still stand today – more than 208 years later – as leit-motifs for the future: tradition and innovation.

**Authors' note** This brief summary of the historical development of the Universalmuseum Joanneum is an extended and updated version of

Peitler, K., Muchitsch, W. und Moser, B.:  
Zur Erweiterung der Kenntnisse, Belebung des Fleißes und der Industrie ...  
Stationen der Entwicklung des Landesmuseums Joanneum.  
In: Wohinz, J. W. (Hrsg.): Nikola Tesla und die Technik in Graz, Graz, 2006, S. 64 - 78.

**References** Binder, Dieter A. (1983): Das Joanneum in Graz – Lehranstalt und Bildungsstätte. Ein Beitrag zur Entwicklung des technischen und naturwissenschaftlichen Unterrichts im 19. Jahrhundert. – Publikation aus dem Archiv der Universität Graz, 12, Graz, 302 S.

Bogner, Dieter, Kunsthaus Graz AG (Hrsg.) (2004): A friendly Alien. Ein Kunsthaus für Graz. – Verlag Hatje Cantz, Ostfildern-Ruit, 252 S.

Göth, Georg (1861): Das Joanneum in Gratz. Geschichtlich dargestellt zur Erinnerung an seine Gründung vor 50 Jahren. – Verlag A. Leykam's Erben, Graz, 323 S.

Mell, Anton (Red.) (1911): Das steiermärkische Landesmuseum Joanneum und seine Sammlungen 1811 – 1911. – Ulrich Moser Buchhandlung, Graz, 520 S.

Muchitsch, Wolfgang (2002): Vom innerösterreichischen „National Musäum“ zur GmbH. – In: Eitner H. et al. (Hrsg.): Res Publica – Festschrift für Peter Schachner-Blazizek zum 60. Geburtstag, Verlag Leykam, Graz, 455 – 475.

Pakesch, Peter & Muchitsch, Wolfgang (Hrsg.) (2011): 200 Jahre Universalmuseum Joanneum 1811 – 2011, Verlag Universalmuseum Joanneum, Graz, 259 S.

Pickl, Othmar (Hrsg.) (1982): Erzherzog Johann von Österreich. Sein Wirken in seiner Zeit. Festschrift zur 200. Wiederkehr seines Geburtstages. – Forschungen zur geschichtlichen Landeskunde der Steiermark, Band 33, Graz, 284 S.

Sutter, Berthold (Hrsg.) (1969): Festschrift 150 Jahre Joanneum 1811 – 1961. – Joannea Band II, Verlag Styria, Graz, 427 S.

The architecture of  
the high-voltage laboratory:  
An exciting architectural  
monument to technology

by Friedrich Bouvier

Fig.: Nikola Tesla Laboratory – exterior view (photo: H. Tezak).





The building complex of the electrical engineering institutes of Graz University of Technology, erected around 1970 on the so-called Inffeld grounds, today consists of teaching and research institutes for high-voltage engineering, construction and operation of electrical installations and networks, electric drives and motors, energy management, high-frequency engineering, electronics, communications engineering and wave propagation.

Particularly interesting and striking, the high-voltage test hall was designed by architecture professors Hubert Hoffmann and Ignaz Gallowitsch and their staff and assistants at the time, Albin Bulfon, Heiner Hierzegger, Annemarie Hierzegger, Annemarie Obermann and Herrad Spielhofer.

The high-voltage laboratory planned and built between 1965 and 1972 in the course of the construction of the entire institute building is the result of a competition in whose success Hubert Hoffmann's employees played a major role. When the competition jury awarded the contract, Hoffmann hesitated to accept the commission. It was only at the insistence of his employees, some of whom were or are still active in teaching, that the extremely interesting assignment was accepted and the winning project realised.

The architectural work of the high-voltage hall, marvelled at by many after its construction, fulfils one of the important quality criteria of architecture: the harmony of form, construction and function.

Even the strictly cubic outer form, without any recognizable openings, allows a technical content to be easily deduced.

---

### Design principle

The design principle is clearly legible. The load-bearing static construction of the hall is clearly visible on the outside of the building. Tubular profile steel truss frames cover the outer facing of the building. These steel truss frames, triangular in cross section, rest on points and are stiffened by diagonally arranged slim steel tube profiles to absorb horizontal forces.

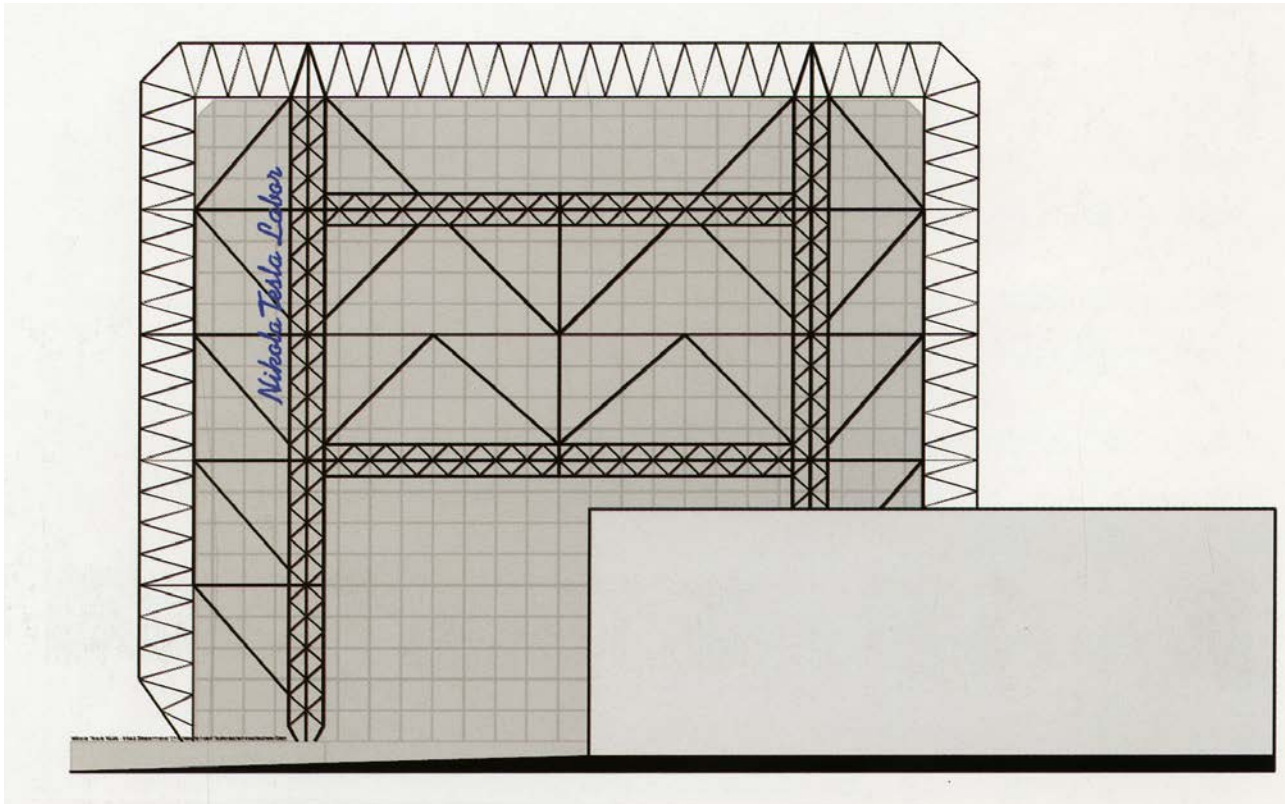

The spatial envelope – a cube with bevelled vertical corners – must meet special technical and physical requirements, in particular the necessary shielding. A technically sophisticated sandwich construction fulfils these requirements. Behind the outer cladding of square corten steel plates with a diamond cuboid surface structure is a densely welded steel construction made of profiled sheets. All cables leading into or out of the hall are routed through special filters so as not to impair this shielding. This makes it possible to produce test voltages of more than one million volts within the hall and simultaneously record signals of the order of one millionth of a volt.

Fig.: Design for the renaming of the high-voltage hall as the Nikola Tesla Laboratory (by Elisabeth Scharinger and Ines Seethaler).

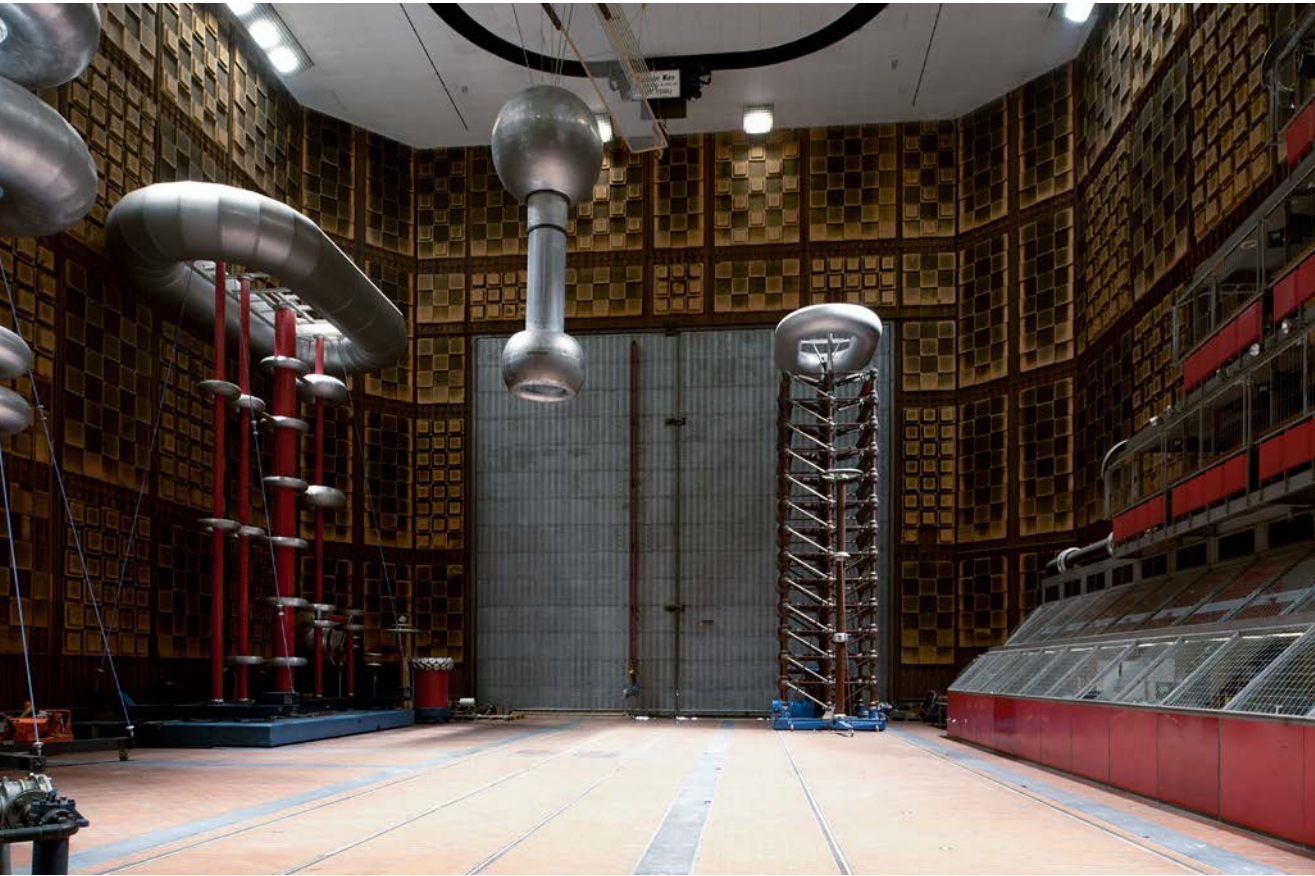
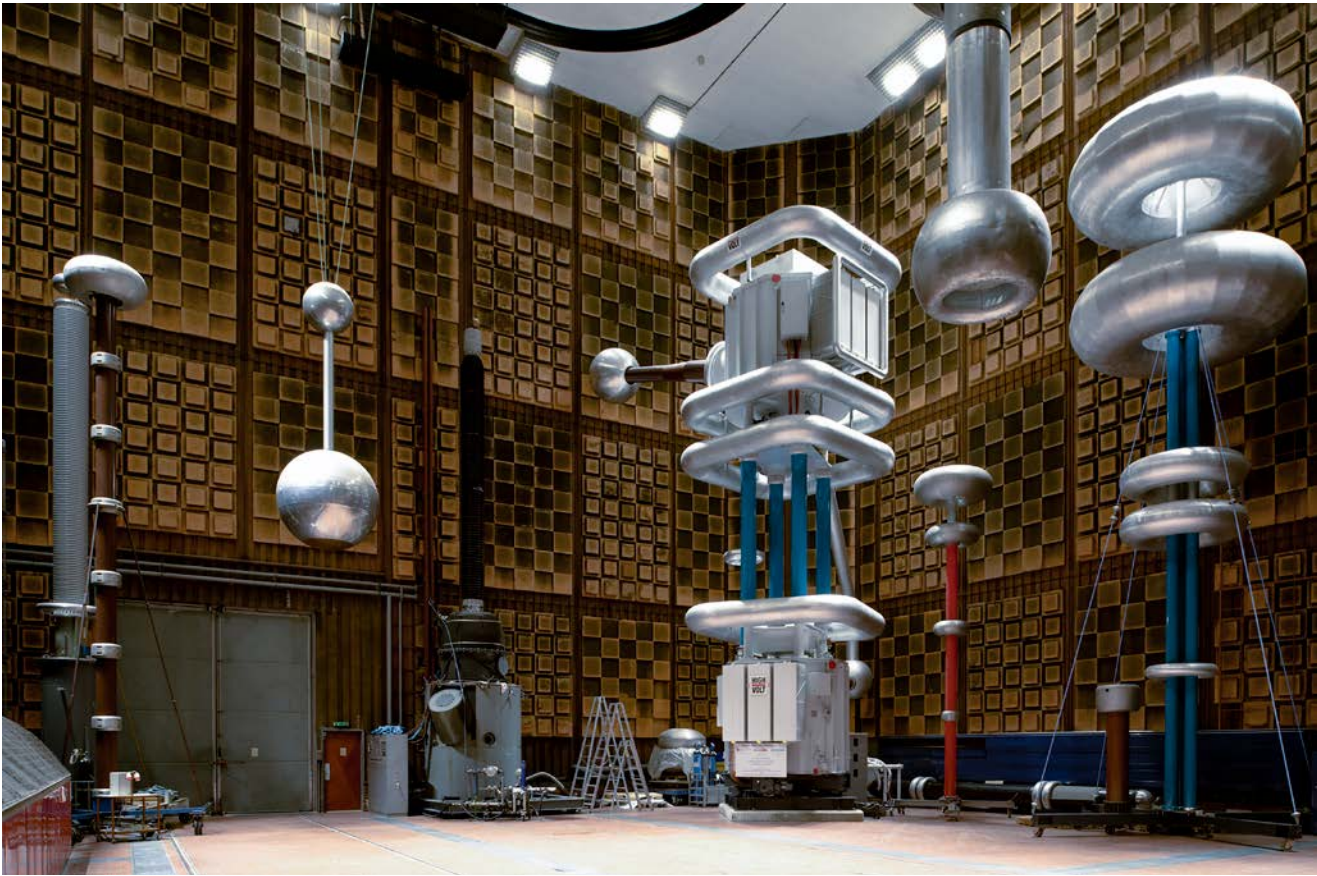

Fig.: High-voltage hall – interior view (photo: H. Tezak).

The interior is 35 metres long, 25 metres wide and has a clearance height of 21 metres. Behind the interior larger chamfered corners there are climbing aids and installations. For acoustic reasons, the laboratory hall is lined with acoustic elements on the inside. On the western narrow side of the hall, a large two-leaf hydraulically controlled gate with a height and width of 14 metres enables the installation of large and heavy equipment. A single firmly anchored truss frame girder, similar in design to the hall frames, located at a distance outside this hall gate, has the function of a portal crane. Rails lead from the outer por-



tal crane into the interior of the high-voltage hall, in which one crane can carry 12 tonnes and one crane 5 tonnes of payload. According to an initial concept, the rails were to be routed to Graz East railway station. A secure and shielded gallery allows teaching activities to be integrated into the laboratory hall.

Fig.: High-voltage hall – interior view (photo: H. Tezak).

Functionally, the high-voltage laboratory has fulfilled four essential tasks to date:

- High-voltage experiments as part of teaching for students
- Basic research (e.g. insulation systems, lightning discharges)
- Research in cooperation with companies (e.g. insulation materials)
- High-voltage tests for electrical equipment (e.g. overhead line fittings, instrument transformers, high-voltage cables)

---

#### Tasks and test facilities

For these functional requirements, the following prerequisites and test facilities are available:

- Shielding attenuation: 100 dB
- Alternating voltage cascade: 1500 kV, 50 Hz, 1500 kVA
- Direct voltage cascade: 1500 kV, 20 mA continuous
- Impulse voltage generator: 2900 kV lightning impulse  
1800 kV Switching surge negative  
1400 kV switching surge positive
- Insulating-oil processing and vacuum plant
- 1100-kV bushing with test vessel
- Open-air test area for tests under wet conditions

While architectural critics initially suspected futuristic perspectives in the technical design of the high-voltage laboratory as a symbol of the hopes associated with technology in the 1960s /1/, today it must be stated that the architecture of the hall has not lost its formal and constructive fascination after almost 50 years. On the contrary, in its timeless architecture characterised by function, it has become an example of high aesthetic quality.

By naming the high-voltage hall after the name of the pioneer of alternating current technology, Nikola Tesla, on the occasion of his 150th birthday on 10 July 2006, interest is directed to a great scientist of electrical engineering and at the same time to an exciting monument to technology.

**Postscript** The author would like to thank Univ.-Prof. Dipl.-Ing. Dr.techn. Heiner Hierzegger for information about the competition and Dipl.-Ing. Dr.techn. Werner Lick for information about the technical features of the building.

**References** /1/ Friedrich Achleitner, Österreichischer Architektur im 20. Jahrhundert, Band II, Salzburg 1983

'Technology is the pride  
of our age'

(Peter Rosegger)

A technological history  
of Graz in the 19th century

by Gerhard M. Dienes

The 'history of technology', Eberhard Franz writes in the book '130 Jahre Südbahn' (130 years of the Southern Railway), 'is the history of change made to the earth by man. Through the senses man perceives his environment, with his mind he grasps it, with the skill of his hands he shapes it in a visible way and thus subjects the earth to constant change. This shaping of the earth carried out by man serves primarily to cover the needs necessary for maintaining life. But it goes far beyond that: it includes focusing on the satisfaction of all the needs arising from the mind of man. These range from the urge to dominate the earth to longing for the beautiful and to grappling with the unfathomable. Whether a ploughshare, a sword or an image of the deity – there is always a need for what we call technology. And the history of technology consists of ever new episodes of thought, creativity and application.'

Technological development is subject to economic principles. Usually only those technical advances which appear advantageous from an economic point of view have any real chance of realisation.

Since technology contains in itself an autonomous value gradient, as a rule the economy provides the basis for decisions for the realization of alternative technical processes and different theoretical possibilities of decision.

The emergence of the capitalistic economic system stimulated the search for efficient production routes. Even a critic of capitalism, like Karl Marx, would not fail to recognize its innovative power. It is no coincidence that those economic revolutions which brought about special modernisation pushes were closely linked to the economic principle of gainful employment.

The example of the first Industrial Revolution in particular illustrates how closely technical development was and is integrated into the social, economic and political environment.

The term 'Industrial Revolution', coined by Arnold Toynbee, is not entirely unproblematic, since revolutions usually refer to sudden transformations that [in this context] changed the face of England between c. 1780 and c. 1850. It was characterised by self-renewing economic growth with continuous technological innovation.

The Industrial Revolution transformed people from agricultural labourers into actuators of machines powered by inanimate energy.

By the middle of the 18th century, steam had already been successfully harnessed as a driving force for machines. The steam engine set the 'revolution' in motion and shaped it.

The combination of criteria which was the Industrial Revolution reached the European continent and Austria, which was sceptical about the innovations, in a historical phase shift.

The Habsburg monarchy became a source of impetus in the person of Archduke Johann who, in contrast to his imperial brother Franz I, was one of those 'who, through reform, revolution and war, steered the old Europe out of its agrarian-feudal circumstances and into the modern world, into the bourgeois, industrial age'. (Grete Klingenstein)

Styria and its capital became a place of his innovative activities.

'It is necessary to acquire the knowledge of new technologies,' noted the Archduke. On a journey to England, he supplemented his level of technical knowledge and recognised how to make up for the backwardness of his domestic economy: raw materials and energy had to be made available as important elements in production at acceptable prices in order to ensure competitiveness.

The use of coal to help stem the energy shortage caused by the limited timber resources.

Adjustment of transport capacities to the sharp rise in trade.

Of great importance was Johann's interest in technological problems in connection with his efforts to modernize mining, industry and agriculture, whereby the so-called Agrarian Revolution of the late 18th and early 19th centuries consisted less in introducing new labour-saving machines and techniques than in intensifying the use of land and labour.

Johann, who initiated the Agricultural Test Facility in Annenstrasse, Graz, was convinced that the entire technology and its industrial application had to be based on a scientific but practice-oriented foundation, without losing its orientation towards practice.

This view finally led to the founding of the Joanneum in Graz in 1811, which ultimately corresponded to the rapid development in all areas of technology and was also intended to be a museum of technology from the outset. At the Joanneum, in the State Library, in his own industrial enterprises, in the mining college at Vordernberg and in agricultural sample goods and in the construction of the Semmering railway, the enlightened technocrat Johann lent a hand to bring about progress and have it brought about.

The leading sciences of the day were botany and mineralogy, both closely connected to a practical world 'hungry for improvement' comprising agriculture, medicine – especially homeopathy, mining and metallurgy, manufacturing and dyeing technology, transport and the military.

At the instigation of Archduke Johann, a systematic survey of the geognostic conditions in Styria was started in 1811. Begun by Friederich Mohs, whose scale of hardness is still used for mineral classifications today, it was continued from 1817 by Mathias Josef Anker. Its result was the establishment of the Styrian Technological Mineral Collection at the Joanneum, which served primarily to inform prospectors, tradesmen and manufacturers, as well as a mountain map of the country drawn up according to an English model.

The Joanneum also included a collection of machines which, as Gustav Schreiner noted in 1843, 'serve an excellent purpose for teaching ... and therefore very expensive machines and models are not to be found here. However, the older engines should be quite complete, including a steam engine of the old type ...'.

The university, which evolved out of the Lyceum, also had such a collection called the Physics Cabinet. It contained 'over a thousand items, part instruments, part physico-chemistry apparatus, which do not only include everything necessary for teaching, but are also remarkable for the optical, magnetic and electrical instruments, which have been particularly propagated in recent times.' (Gustav Schreiner)

However, mechanisation and industrialisation also met with distrust and even resistance.

Industrial hostility can be detected early among the population living close to the factories because of the smoke, roar and stench. Craftsmen saw themselves increasingly in competition with machines, and factory owners also tried to circumvent legal regulations for the sake of their profits.

However, there was a lack of a real mercantile and upper middle class in the city and countryside. In addition, wheel makers and hammer masters had difficulty adapting to the changed conditions and complained about the English competition.

Archduke Johann also founded the Steiermärkische Sparkasse in 1825. Not least, it was meant to put a stop to usury, which largely dominated the domestic capital market.

Thanks to his initiative, an association was founded two years later for the 'promotion and support of industry and trade in Inner Austria'.

Johann recognised how much technology and education depended on each other. He saw that the upheaval of the technological foundations and the expansion of trade placed completely new demands on the people involved in the production and circulation process, both entrepreneurs and workers. As long as technical inventions could not be put into practice due to a lack of knowledge or because trade connections were not used or the entrepreneur concerned could not conduct the necessary 'correspondence', successful action was not possible.

The development of a corresponding educational infrastructure was therefore a basic condition for the capitalist mode of production. In order to remedy the shortcomings in this area, the trade association organised easy-to-understand lectures on science and set up so-called drawing institutes in Graz, Klagenfurt and Ljubljana for further training, where the most important technical books and journals were published in its own libraries.

In 1832 a trade exhibition took place in Graz and the industrial exhibition of 1841 had a stimulating effect on the economic development of the city. The decisive growth spurt, however, was only to begin in the aftermath of the revolution of 1848.

Although Graz was not a 'factory town in the Biedermeier period, like Brno, the city of Steyr and others', according to Gustav Schreiner, the city nevertheless possessed 'some major trades which belong to the more excellent of the monarchy'.

There was the 'optical, geometric and physical' machine factory of the Rospini brothers in Bürgergasse. Here, physical and meteorological observations were carried out from a tower.

There was the Jäckle large clock factory which would export to America and other companies.

The first factory in the modern sense of the word was the sugar refinery in Geidorf, which was founded in 1825 with capital from the Jewish Viennese bank Arnstein & Eskeles. With 110 workers, it was the biggest factory of its kind in Austria. It contained the first ever steam engines in Styria, which still had to be imported.

Fig.: The sugar refinery in Geidorf (from: Frankensteins Fabriks-Bilder-Atlas 1843).



*Ansicht der k. k. priv. Grätzer Zucker- Raffinerie!*

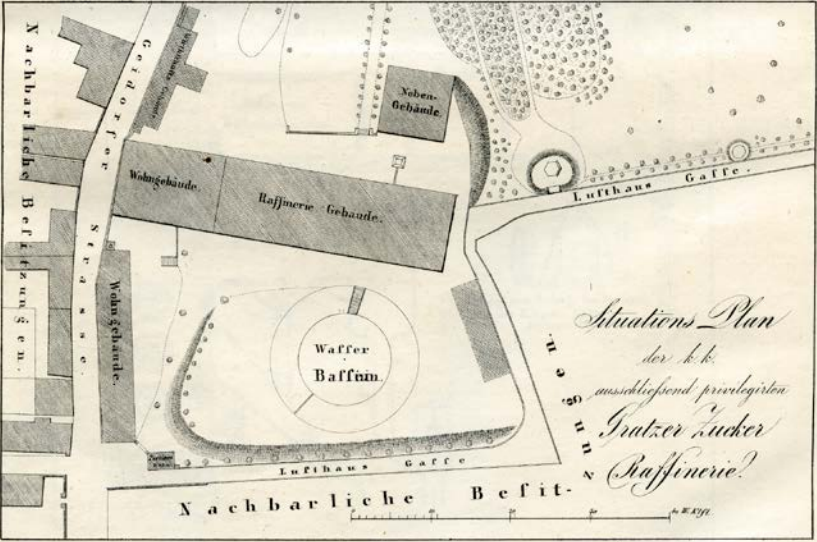

Taf. III. Von F. Krieger



*Ansicht der k. k. Landespriv. Maschinen-Papierfab. des Herrn Friedrich Lenk in Grätz.  
(Firma And. Leykems Erben)*

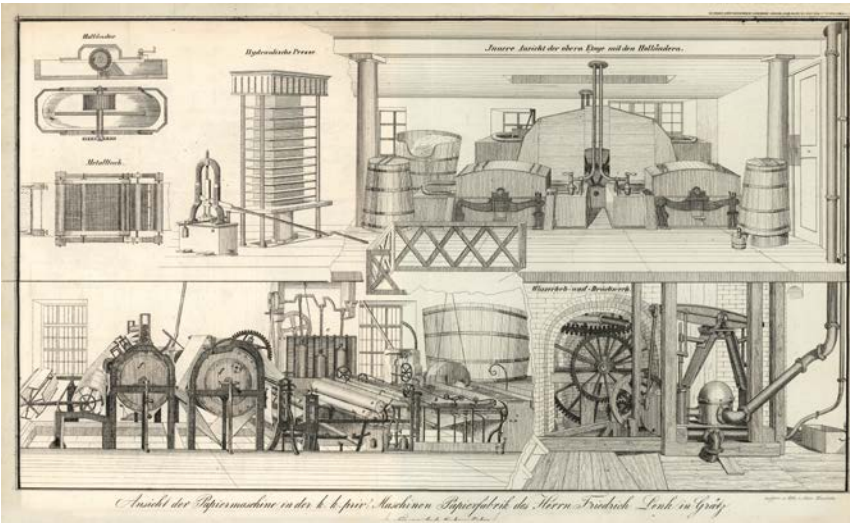

*Ansicht der Papiermaschine in der k. k. priv. Maschinen-Papierfab. des Herrn Friedrich Lenk in Grätz.*

Fig.: The Leykam paper factory in Graz (from: Frankensteins Fabriks-Bilder-Atlas 1843).

In the building industry, especially in bridge construction, technical progress was demonstrated by the use of iron. The first large bridges of the time were chain bridges, where the roadway between two brick chain houses was suspended by tensioned chains. An early example of this is the Emperor Ferdinand chain bridge (Kepler bridge) opened in 1833. It was regarded as a miracle, as an expression of modern building convictions and even found its way into the theatre through the farce 'Die Bekanntschaft auf dem Glacis, die Entführung auf dem Ruckerlberg und die Verlobung auf der Kettenbrücke' (Acquaintanceship on the Glacis, abduction from the Ruckerlberg and betrothal on the chain bridge.)

After all, this bridge – the Biedermeier period was not so conservative at all – is the most common of all the motifs of the Graz veduta painter Conrad Kreuzer. Kreuzer lived with his family near the bridgehead in Lend (on the right-hand side of the river).

Not only did Kreuzer devote his artistic expressions to the new achievements of technology. Carl Reichert and Joseph Kuwasseg also did this, and Vinzenz Reim captured the 'Iron House' in one of his paintings.

This was built in 1847/48 on Murplatz (today's Südtirolerplatz) according to the plans of Josef Benedikt Withalm. The cast iron skeleton of the upper floor of the building, which was erected as a café, is one of the very early international examples of the use of iron in building construction.

Withalm had already caused a stir years earlier with the construction of the Coliseum, a 'hall for all'. In 1843 the 21st meeting of German natural scientists and doctors took place in the Coliseum. Participants included the chemist, Justus Liebig, the founder of mathematical physics, Andreas Ettinghausen, and the railway builder, Carl von Ghega.

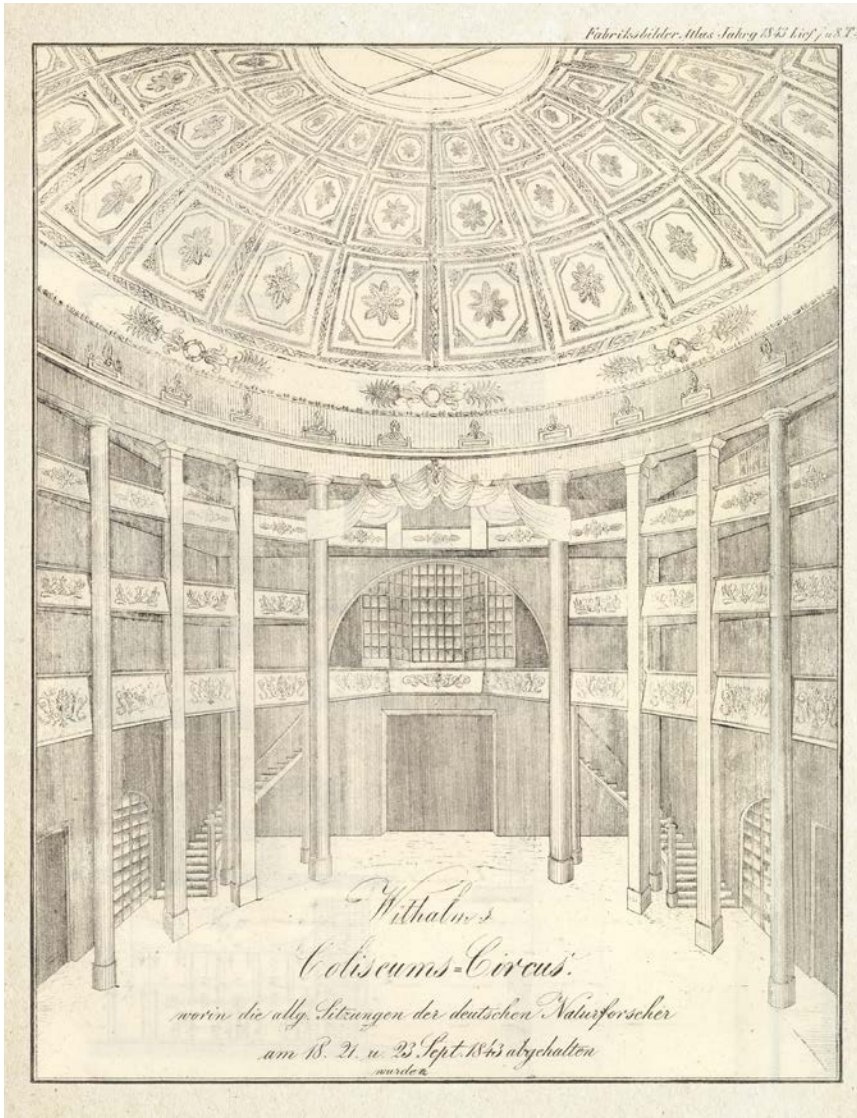

Fig.: Interior view of the Graz Coliseum (from: Frankensteins Fabriks-Bilder-Atlas 1843).

For Graz, the age of the railway began on 21 October 1844 with the opening of the Southern Railway section from Mürzzuschlag to Graz.

One of the most important initiators of the Southern Railway connecting the Danube basin and the Adriatic Sea was Franz Xaver Riepl. Born in Graz, he worked as a professor of mineralogy and commodity economics at the Vienna Polytechnic. In 1824 Archduke Johann commissioned him to reform the iron industry at Erzberg in Styria. Riepl recognised that the invention of the steam railway in England could only be put into practice because the English iron industry had already reached such an advanced level of technology that it was possible to produce railway tracks, steam boilers and locomotives. If Austria wanted to build steam engines, it had to overcome its backwardness beforehand.

This in turn necessitated the introduction of hard coal in the smelting industry and the construction of rolling mills based on the English model instead of the iron hammers previously used. In Witkowitz/Vitkovice (Czechia) Riepl was able to put his ideas into practice.

Finally, he developed the project of a locomotive railway from Vienna via the Ostrava coal district and the salt deposits in Bochnia in Galicia to the Russian border near Brody and from Vienna to Trieste, a stretch of 1,500 kilometres across the Danube Monarchy.

Riepl's Northern Railway was made possible by the banker Salomon Rothschild. The first section from Floridsdorf to Wagram was opened on 17 November 1837.

Soon the rails extended from Vienna to the south.

In 1842 the first Southern Railway section to Gloggnitz was completed. Carl Ritter von Ghega was responsible for the planning and execution of the further route to the Adriatic.

Without Archduke Johann, however, this railway would not have passed through Styria. It was Johann who created the conditions for the construction of the first railway line crossing the Alps, the Semmering railway.



The Semmering railway is not only inseparably linked to Ghenga, but also to Wilhelm von Engerth.

Engerth had been professor of mechanical engineering at the Joanneum in Graz since 1843, later he joined the Department of Railway Mechanics of the Ministry of Trade and Industry. As a result of a competition, Engerth developed the world's first usable mountain locomotive for the Semmering railway. Engerth locomotives were not only used on the Semmering, but also on the karst section of the Southern Railway.

Finally, Engerth locomotives, developed in a large-wheeled version for lowland routes, were also used outside Austria, especially in France and Switzerland. Josef Herr, from 1852 to 1857 professor of higher mathematics, theoretical and practical geometry at the Joanneum, was also closely associated with railway construction. He gained his first professional experience during the construction of the Hungarian Central Railway, the Danube survey and the Semmering railway. Later he was head of the first special school for higher geodesy and spherical astronomy in Europe at the Vienna Polytechnic. In 1866/1867 he was the first elected rector of the Technical University in Vienna.

Fig.: Graz main railway station in 1844. From: Demarteau, *Malerischtechnischer Atlas der k. k. Staatseisenbahnstrecke von Mürzzuschlag bis Glatz in Steiermark* (TU Graz Archive).

The consequences of the revolutionary uprisings of 1848/1849 represented a water shed on the path to the world of today. They brought basic relief and abolition of serfdom, the end of feudal rule, the freeing up of scholarship and teaching, and the liberalisation of trade and industry and industrial capitalism.

The second half of the 19th century was influenced by countless fundamental discoveries in practically all areas of science. Technology experienced the implementation of new scientific knowledge, particularly in the development of electrical engineering and chemical industries. The possibility of cheap steel production through the development of the Bessemer converter and the Siemens-Martin furnace heralded a new era: Steel replaced iron and, thanks to its extreme load-bearing capacity, allowed the construction of huge structures as well as more powerful (because more load-bearing) machines. Railway, ship and building construction are just some of the buzzwords that represent the triumphal procession of steel, the production volume of which increased fortyfold worldwide between 1870 and 1900.

Many fundamental inventions were made during this period, such as Graham Bell's telephone in 1876, Siemens' alternating current generator in 1878, Edison's light bulb in 1879, Otto's four-stroke engine in 1876, or aspirin as the first synthetic remedy in 1899.

Alfred Nobel's dynamite was not only to be used – as intended – in tunnelling and mining, because the military soon became interested in this new substance, which soon revolutionised warfare.

Graz played a not inconsiderable role in this development through the University and the College of Technology which emerged from the Joanneum.

Ernst Mach, August Toepler and Ludwig Boltzmann, one of the greatest natural scientists of all time, worked in Graz. Philipp Forchheimer, professor of hydraulic engineering and a walking encyclopaedia of engineering sciences, experienced international resonance with his work, Friedrich Reinitzer discovered liquid crystalline properties, Friedrich Emich quantitative inorganic micro-analysis, Karl Wilhelm Friedrich Kohlrausch dedicated himself to the problems of atmospheric electricity and radioactivity, Robert Honold became Viktor Kaplan's adversary in the field of hydroelectric machines, Richard Zsigmondy, who later won the Nobel Prize, began his pioneering work on glass and porcelain colours in Graz, August Musger succeeded in inventing slow motion and Otto Nußbaumer the first wireless music transmission.

There were more and more inventions, some significant and some less eminent, such as those advocated in the evening edition of the 'Grazer Zeitung' on 3 October 1857:

'Latest invention / in the field of chemistry! / With greatest benefit applicable to any household, especially for the hospitality trade and / such larger establishments / Washing Method / in which way, according to the recipe, the laundry is not / ground, you need very little wood / time and effort and significantly save on soap / instead of using 2 pounds you just need  $\frac{1}{4}$  pound /. The inventor guarantees the genuineness of the method and ensures that there is no / fraud behind it. These recipes / are available in a sealed condition for the whole of Styria: / in Graz in the toy shop of Mr J. A. Sanoner in Murgasse.'

The city of Graz itself was at the beginning of modern economic growth in the middle of the 19th century. The guilds had been dissolved, and the era of economic liberalism was beginning. The economy expanded almost explosively, and the first big wave of industrialisation commenced.

At that time, world expositions boasted magnificent technology and symbolized that the dream of mankind of 'higher, faster, further' finally seemed to come true with the beat of the steam engines. At the World Exposition in Vienna in 1873, a monumental show fountain designed by the sculptor Baptiste Jules Klagman and cast by Antoine Durénne in Paris illustrated the connection between art and technology. Its final resting place was to be in the Stadtpark (Graz city park).

Graz joined this almost global trend of expositions, albeit on a modest scale, and organised the Industrial and Agricultural Exhibition at the Agricultural Test Facility in 1870. Later, the industrial hall was built for this purpose, in which the Graz Trade Fair, the first of its kind in Austria, was to take place in 1906.

The stock market crash of 1873 put an end to the economic boom, but the belief in the economic upswing still seems to have been unbroken, and at the beginning of the 1880s the Graz economy had also overcome the recession. The following late founding phase (Gründerzeit) brought the city industrially and technologically forward again.

On the downside of economic prosperity, however, were increasingly the lower social classes, day labourers, maidservants and industrial workers. Their working and living conditions were dismal. About half of the dwellings in Graz consisted only of a room and a kitchen. A lack of basic sanitation facilities was the rule. The share of substandard basement and attic dwellings was above the average of the entire monarchy and even higher than in Vienna and Prague. A lack of basic sanitation facilities was the rule in these dwellings:

they were untouched by the technical advancements of electric light and water pipes.

The city's central water supply, also a technical novelty, was instituted in 1870. The low water rates meant that consumption per capita per day rose to 170 litres by 1897. Only the need after the end of the First World War brought about the introduction of water meters.

A strong driver of Graz industry was the railway.

The industry needed an efficient transport system and Graz became a railway hub.

In 1857 the Southern Railway from Vienna via Graz, Marburg/Maribor and Laibach/ Ljubljana to Triest/Trieste was continuously accessible. The economic life of the city was substantially invigorated by this. The markets of the Levant opened up for Graz via the port of Trieste.

In 1860 the Graz-Köflach railway was inaugurated. It facilitated the supply of energy from the west Styrian coal district.

In 1873 the western Hungarian or Raab railway (from today's Graz East railway station) was completed in Graz, connecting the city with a traditional trading area in southwestern Hungary.

Since the Middle Ages, the two mill streams in Graz had been of great economic importance, as water was the most important source of industrial power until the 19th century.

Since the end of the 'pre-March period', industry in the Styrian provincial capital had increasingly begun to make use of steam power. In 1850 there were nine steam engines in Graz, and a decade later there were already thirty. The companies increasingly settled near the railway, where the supply of coal and raw materials was easy. An industrial zone developed along Schienenstrasse.

Mechanical engineering, metalworking and brewing proved to be the dynamic branches of the modern Graz economy.

In the brewery of the Reininghaus brothers on Steinfeld, the first pressed yeast factory in Styria was built. Humanic, the largest shoe factory in Central Europe at the time, was probably the first shed roof construction on the continent.



Fig.: Advertisement for the Puntigam brewery from 1906 (Adressbuch der Stadt Graz, 1906).

The rail rolling mill was at the cutting edge of technology, headed by Joseph Hall, an English engineer trained by locomotive pioneer George Stephenson. In 1856 the Bessemer process was introduced to increase production. The Southern Railway was the first Austrian railway to run on Bessemer rails; and 1870/1871 saw the ignition of the first Siemens-Martin open hearth furnace not only in Graz, but in the whole country.

The Andritzer Maschinenfabrik company, founded by the Hungarian iron entrepreneur Josef Körösi in 1852, became the first establishment in Styria to produce steam engines on a large scale. As early as 1857, 'Andritz' supplied larger steam hammers and steam engines for the entire metallurgical facilities of the new plant in Eibiswald and for the generously proportioned plant in Pichling. It should be mentioned in particular that the 11,000 HP triple-roller traction unit produced in Andritz for Donawitz was one of the heaviest machines on the soil of the Danube Monarchy. 'Andritz' achieved a leading position in centrifugal pump construction, further developed crane construction and manufactured 347 water turbines up to the outbreak of the First World War.

In 1872 the Andritz machine works built an independent department for bridge construction. The plant, located on the Southern Railway, later became the Graz works of Waagner-Biró AG. Various bridges for the Arlberg railway, the famous Trisana bridge, the bridges for the Vienna city railway and the Bosnian provincial railways were built here.

As in the Biedermeier era, Graz proved to be open to technical innovations in bridge construction during the Gründerzeit. The Mur crossing, which replaced the Ferdinand chain bridge (Kepler bridge) in 1882, formed the prototype for the system of the 'Langer beam' (arched bridge). The design aroused admiration in the professional world and found appropriate mention in the technical literature.

Founded in 1854 by Johann Weitzer, the blacksmith's and coachworks was to develop into a world-renowned company by expanding the railway network and specialising in wagon construction.

Fig.: Advertisement for the Weitzer machine works from 1907 (from: Elektrotechnik und Maschinenbau, 1907).



**Grazer Waggon- und Maschinenfabriks-**  
**Aktien-Gesellschaft**

vormals  
**Joh. Weitzer**  
**Graz.**

Erzeugung aller Arten Betriebsmittel für Normal-, Schmalspur-, Wald-, Feld- und Industriebahnen, sowohl für Dampf- als auch elektrischen Betrieb.

**Erzeugung des Wärme-Motors, System Diesel.**

Übernahme von Arbeiten und Reparaturen aus dem allgemeinen Maschinenbau. — Modern eingerichtete Schmiede- und Appreturwerkstätten für Lieferung aller Arten Schmiedestücke, roh und bearbeitet.

*Ausführung rasch und billige Preise.* 745

Weitzer wagons went to Turkey and Egypt, to India and Java, to China and Australia. Tram sets were also produced. Since 1899 'Weitzer' (later SGP, Graz works) has also been a centre of diesel engine construction. The company shaped the development of rolling stock for electric railways and created lasting constructions in this special field. Almost all electric trams and local trains in Austria and partly in Hungary were supplied from here with trams, trailers and electric locomotives.

What Weitzer was for rail, Puch was for two and four wheelers. The factory founded by Johann Puch, a locksmith from Pettau/Ptuj, supplied its 100,000th bicycle as early as 1908, and eleven motorcycle models and 21 car types were produced by 1914.

Johann Puch also supplied the engine for the first independently guided airship of the Danube Monarchy, with which the brothers Alexander and Anatol Renner took off at the 1909 Graz Autumn Fair.

The new industries needed additional energy, be it coal, gas or water. But electricity also increasingly appeared as a form of energy, albeit initially for lighting.

Graz proved to be backward in this respect, so that the social democratic newspaper 'Arbeiterwille' issued the following admonishment:

'How many years have they [the inhabitants of Graz] had to endure scorn and ridicule over the lack of what hundreds of villages already possess: electric light in adequate amounts.'

The city in which direct current had been distributed had become a current vacuum after 1900. Private electricity producers, like Viktor Franz in Gösting, settled outside the city. In 1903, a power station went into operation in Lebring, on the cataract section of the Mur, whose current was converted to a voltage of 200,000 V (20kV) by means of transformers for the first time in the monarchy and was therefore suitable for being supplied economically to the consumer centre Graz.

But Graz was ignorant of technical progress when it came to sewage systems. Since 1867 there was the barrel system for the disposal of faeces. The contents of the so-called barrel apparatuses were plunged into the Mur or given to farmers. After the introduction of flush toilets, difficulties arose as the barrels were now filled much faster. So a sewer system seemed an absolute necessity. There was much discussion about it, but construction only began as late as 1925. In this respect, Graz was one of the most backward cities in the German-speaking area.

Fig.: Advertisement for the Puch company from 1899 (Grazer Tagblatt, 1899).

**Verlangen Sie**

den **Haupt-Katalog** über



**Puch-Rad**

und studieren Sie solchen sorgfältig! Sie werden dann keine Minute mehr zweifeln daran, daß Sie kein anderes Rad fahren können, um nach jeder Richtung hin

**sicher**

zu sein. 128-9

**Puch's patent. Transportrad**  
das einzig praktische Geschäftsrads für Transportzwecke ist

**unerreicht**

hinsichtlich Dauerhaftigkeit, Tragfähigkeit und leichtem Lauf.

**Johann Puch**  
Fahrrad-Werke  
Niederlage } **Graz**  
u. Fahrtschule } Joanneumring 20.

**Gut**

ist nicht ein Rad bloss, weil es durch markt-schreierische Reclame angepriesen wird!

**Billig**

ist nicht ein Rad bloss, weil es zu einem Schlenderpreise ausgeben wird!

**Gut u. billig**

ist nur jenes Rad, welches alle Vorzüge der modernen Fahrrad-Technik, als: **Präcision, Eleganz** und **Stabilität** in sich vereinigt, wie dies einzig und allein **nur**

**Puch-Rad**

vermag, das unerreicht in seiner **leichten Gangart**, unverwundlich durch **vollendete Construction** und **tadelloses Material** heute als

**bestes Rad der Welt**

dasteht und im Monate Juni allein, in Oesterreich-Ungarn, Bosnien, Belgien, Deutschland, Italien, Rumänien etc.

❧
**62 erste Preise**
❧

**31 zweite ..**  
**28 dritte ..**  
**3 fünfte ..**

zu verzeichnen hat; darunter wurden gewonnen:

**Sechs-Stunden-Rennen zu Budapest, Meisterschaft von Budapest, Meisterschaft von Ungarn, Bergmeisterschaft von Ungarn, Preis der Stadt Wien u. s. w.**

❧ Beim **Gruppen-Rennen in Saaz** waren unter 24 Startenden nur **zwei Puch-Räder** vertreten — **Puch-Rad** passierte jedoch als **ERSTER** und **ZWEITER** das Ziel.

Das echte wirkliche

**Puch-Rad**

ist zu haben:

**Graz, II., Joanneumring Nr. 20**  
**Wien, II., Praterstrasse Nr. 33**  
**Budapest, VII., Elisabethring Nr. 48**  
in den **eigenen** Niederlagen.

Man verlange **Preiscurant** über **Puch-Rad** und Motor-Fahrzeuge sowie Gepäcksdreiräder,

**Johann Puch**

Fahrradwerke

116-12  
**Graz, V., Laubgasse Nr. 6-14.**

Nevertheless, the bourgeoisie as the politically relevant class in its liberal idealism, to follow Stefan Zweig's remarks, was also '... honestly convinced that it was on the straight and unflinching path toward being the "best of all worlds". Earlier eras, with their wars, famines, and revolts, were deprecated as times when mankind was still immature and unenlightened. But now it was merely a matter of decades until the last vestige of evil and violence would finally be conquered, and this faith in an uninterrupted and irresistible "progress" truly had the force of a religion for that generation. One began to believe more in this "progress" than in the Bible, and its gospel appeared ultimate because of the daily new wonders of science and technology.'

But this uncritical belief in technology was increasingly opposed by thinkers and poets, such as Peter Rosegger, who summed up and warned in his 'Heimgarten' periodical in 1909:

'Technology is the pride of our age. Above all, the technology of the machine, in which we have created an iron body for the human body, so that it really seems that we would live firmly in this enduring body, far beyond the death of our flesh. I believe we could say: we are bequeathing our mind to the machine... But what if the future human being is just a machine? What if in the future the machine should replace the human being? I dread this thought. But if we find a balance between technology and soul, between machine and mind, then there is the mediation between the old era and modernity ... If one day it turns out that the victorious technology can make mankind more content, more ethical, happier, then it is divine progress. Otherwise, however, despite all the damaged strength, despite its beauty and splendour, it is a fatal aberration.'

- References** Erzherzog Johann von Österreich. Beiträge zur Geschichte seiner Zeit. Hrsg. von Grete Klingenstein unter Mitwirkung von Peter Cordes, Graz 1982.
- Gerhard M. Dienes, Graz. Eine Stadt vor hundert Jahren. Bilder und Berichte, München 1997.
- Gerhard M. Dienes, Hrsg., Die Südbahn. Vom Donauraum zur Adria (Wien-Graz-Marburg-Laibach-Triest), Graz-Wien 1987.
- Gerhard M. Dienes, Hrsg., „transLOKAL“ 9 Städte im Netz (1848-1918), Graz 1996.
- Gerhard M. Dienes, Franz Leitgeb, Hrsg., Wasser. Ein Versuch. Graz 1990.
- Sokratis Dimitriou, Stadterweiterung. Gründerzeit von Graz. Publikationsreihe des Grazer Stadtmuseums, herausgegeben von Wilhelm Steinböck, Bd. II, Graz-Wien 1979.
- Bedeutende Grazer im Porträt. In Graz geboren – In Graz gewirkt. Hrsg. von Wilhelm Steinböck unter Mitarbeit von Otfried Hafner und Elfriede Turk, Graz-Wien 1977.
- Grazer Industrie hat Tradition. Ausstellungskatalog des Stadtmuseums Graz, Graz 1981.
- William H. Hubbard, Auf dem Weg zur Großstadt. Eine Sozialgeschichte der Stadt Graz 1850-1914. (Sozial- und wirtschaftsgeschichtliche Studien, hrsg. Von Herbert Knittler und Michael Mitterauer, Bd. 17), Wien 1884.
- Franz Jäger, Wirtschaftsgeschichte 1800 bis 2000, in: Walter Brunner, Hrsg., Geschichte der Stadt Graz, Bd. 2, Wirtschaft – Gesellschaft – Alltag, Graz 2003.
- Lichtjahre. 100 Jahre Strom in Österreich, Wien 1986.
- „made in styria“, Katalog zur steirischen Landesausstellung 1997 in Leoben, Graz 1997.
- Gustav Schreiner, Grätz. Ein naturhistorisch-statistisch-topographisches Gemälde dieser Stadt und ihrer Umgebungen, Graz 1843.

Wilhelm Steinböck, Grazer Landschafts- und Vedutenmaler der Biedermeierzeit. Conrad Kreuzer 1810-1861, Vinzenz Kreuzer, 1809-1888. Publikationsreihe des Grazer Stadtmuseums Bd. I, Graz-Wien 1976.

Paul W. Roth, Erz und Eisen in der Grünen Mark. Beiträge zum steirischen Eisenwesen. (Beitragsband zur steirischen Landesausstellung 1984 in Eisenerz), Graz 1984.

Steirische Wirtschaftschronik. Band I mit dem Wirtschaftsgroßraum Graz, Wien o. J.

Justus Franz Wittkop, Europa im Gaslicht. Die hohe Zeit des Bürgertums 1848 bis 1914, Zürich 1979.

Stefan Zweig, Die Welt von Gestern. Erinnerungen eines Europäers (1943), Frankfurt 1993.

- List of authors**
- Bouvier, Friedrich, Dipl.-Ing. Dr.techn., Hofrat  
Em. Conservator for Styria
  - Dienes, Gerhard M., Dr.phil., historian  
Universalmuseum Joanneum
  - Moser, Bernd, Dr.phil.  
Natural History Museum and Centre of Natural History,  
Universalmuseum Joanneum
  - Muchitsch, Wolfgang, Mag. Dr., Hofrat  
Head Office,  
Universalmuseum Joanneum
  - Peitler, Karl, Mag.  
Archaeology Museum and Coin Cabinet,  
Universalmuseum Joanneum
  - Schichler, Uwe, Univ.-Prof. Dr.-Ing.  
Institute of High Voltage Engineering and System Performance,  
Graz University of Technology
  - Wohinz, Josef W., Em.Univ.-Prof. Dipl.-Ing. Dr.techn.  
Institute of Innovation and Industrial Management,  
Graz University of Technology



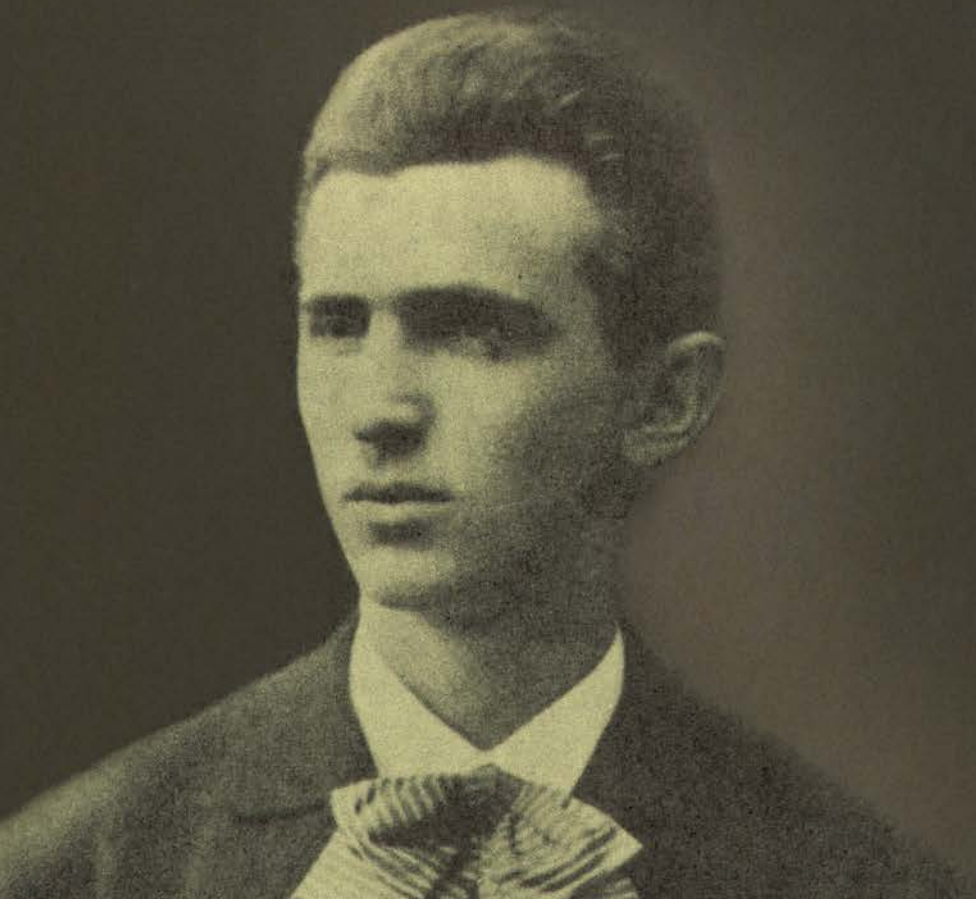

Exceptional personality Nikola Tesla left significant traces during his „Graz years“. In this richly illustrated book, renowned Styrian scientists have set themselves the task of investigating these traces. Embedded in the general technical and economic development of these years in Styria, Tesla's studies come to life again. In addition, one learns how Nikola Tesla's ideas affected science and industry, what development his Graz educational institution, the Joanneum, underwent and how Tesla's legacy still lives today at Graz University of Technology.